



# Tire and Rim Maintenance

## Section 03-08

Komatsu has made every effort to make this manual as accurate as possible based on the information available at the time of publication and printing. Continuous improvement and advancement of product design may cause changes to machines, which may not have been included in this publication. Komatsu reserves the right to make changes and improvements at any time. To ensure the most current information, please contact your service center.

### Table of Contents

- Scope of This Publication, 03-08** ..... 5
- Customer Responsibilities and Warranty Advisories** ..... 5
- Safety**..... 7
  - Safety, Warnings, and Cautions ..... 7
  - Tire Explosion (Safety Hints) ..... 11
- General Introduction** ..... 13
  - Inspect the Work Area ..... 13
  - Inspect the Tires ..... 13
  - Prevent Tire Contact with Oil and Petroleum Products ..... 13
  - Prevent Overloading ..... 13
- Theory of Operation** ..... 15
  - Tramming Guidelines ..... 16
- Component Description** ..... 17
  - Tires ..... 17
  - Tire Inflation/Deflation Valve with Inflator ..... 18
- Circuit Description** ..... 19
- Settings and Adjustments** ..... 19
  - Tire Inflation and Deflation Procedures ..... 19
    - Machine without Chains Tire Pressure ..... 19
    - Machine with Chains Tire Pressure ..... 19
  - Valve System ..... 21
  - Inflation Equipment ..... 21
  - Inflating and Deflating Tires ..... 22
    - Safety Preparations ..... 22
    - Inflating ..... 23
    - Deflating ..... 28
- Removal and Installation** ..... 33
  - Wheel and Tire Removal ..... 33
    - Safety Preparations ..... 33
    - Remove the Tire ..... 36
  - Tire and Rim - Demounting and Mounting ..... 39
  - Maintenance and Handling of Rims ..... 40
  - Wheel Hub Capscrew Removal Specifications ..... 41
  - Demounting Tire from Rim Assembly ..... 42

Inspections of Demounted Tire and Rim Assemblies .....	43
Tire Inspections .....	43
Rim Assembly Inspections .....	43
Mounting Rim Assembly to Tire - Important Safety Information .....	44
Wheel Hub Capscrew Installation Torque Specifications .....	44
Safety Preparations .....	44
Wheel and Tire Installation .....	47
Safety Preparations .....	47
<b>Troubleshooting .....</b>	<b>55</b>
Tire Repairs .....	55
Recapping and Retreading .....	55
Additional Tire Information and Warranty .....	56
Parts Storage .....	56
Storage and Handling of Tires .....	56
<b>Capscrew and Bolt-Nut Torque Specifications .....</b>	<b>59</b>
Standard SAE G8 and Alloy Steel and Hex Socket Capscrews .....	60
Standard Metric Bolts and Grades (SAE J1701M) .....	60
Special Torque Specifications .....	61
Alloy Steel 12PT. Capscrew for Wheel Loader Lift Arm Ballcaps .....	61
Steering Pins (Hex Head Bolt) .....	61
Aluminum 12pt. Capscrews used for Motor Pinion Balancing .....	61
2-Thread (2-Start) Steel 12PT. Capscrews .....	61
Bolt and Capscrew Markings on Head .....	61
Key Items .....	62

## List of Figures

Figure 1.	Tire data plate located on the right side of the front frame .....	17
Figure 2.	Tire valve and inflator components .....	18
Figure 3.	Tire valve .....	21
Figure 4.	Frame lock in locked position .....	22
Figure 5.	Battery Isolation Box – Battery isolation switch in OFF position with locks in place .....	23
Figure 6.	Tire inflation instruction illustrations .....	23
Figure 7.	Tire inflation instructions .....	24
Figure 8.	Tire inflation instruction illustrations .....	24
Figure 9.	Tire inflation instruction illustrations .....	25
Figure 10.	Tire inflation instruction illustrations .....	25
Figure 11.	Tire inflation instruction illustrations .....	26
Figure 12.	Tire inflation instruction illustrations .....	26
Figure 13.	Tire inflation instruction illustrations .....	27
Figure 14.	Tire inflation instruction illustrations .....	27
Figure 15.	Tire Data Plate Located on the Right Side of the Frame .....	27
Figure 16.	Tire deflation instructions .....	28
Figure 17.	Tire deflation instruction illustrations .....	29
Figure 18.	Tire deflation instruction illustrations .....	29
Figure 19.	Tire deflation instruction illustrations .....	30
Figure 20.	Deflation instruction illustrations .....	31
Figure 21.	Tire deflation instruction illustrations .....	31
Figure 22.	Tire deflation instruction illustrations .....	31
Figure 23.	Battery Isolation Box – Battery isolation switch in OFF position with locks in place .....	34
Figure 24.	Hydraulic reservoir air valve handle UP .....	35
Figure 25.	Open air reservoir bleed valves .....	35
Figure 26.	Pressure bleed down valves .....	36
Figure 27.	Mechanical handler (preferred method) .....	36
Figure 28.	Alternative tire handling method .....	38

Figure 29. L-1350-L-1850-L-2350 wheel capscrew removal pattern – models 51, 51A2, 51A3, and 57 planetary drive ..... 41

Figure 30. Typical rim assembly ..... 42

Figure 31. Battery Isolation Box – Battery isolation switch in OFF position with locks in place ..... 45

Figure 32. L-1350-L-1850-L-2350 wheel capscrew installation torque pattern – models 51 and 57 planetary drive ..... 47

Figure 33. Battery Isolation Box – Battery isolation switch in OFF position with locks in place ..... 48

Figure 34. Hydraulic reservoir air valve handle UP ..... 49

Figure 35. Open air reservoir bleed valves..... 49

Figure 36. Pressure bleed down valves..... 50

Figure 37. Capscrew lubrication ..... 52

Figure 38. Capscrew/hardened flatwasher installation – wheel attachment ..... 53

Figure 39. Hardened flatwasher – wheel installation..... 53

## List of Tables

Table 1. Tire and rim sizes ..... 17

Table 2. Tire size and inflation data - recommended cold tire inflation pressures ..... 19

This Page Intentionally Left Blank

## Scope of This Publication, 03-08

Tires are a significant part of overall equipment expenses, and their maintenance can greatly affect productivity. Familiarizing yourself with the information in this publication and contacting the tire manufacturer for additional information will reduce the expenses associated with the tires on the machine and increase productivity.

## Customer Responsibilities and Warranty Advisories

P&H wheel loaders are warranted in accordance with the warranty policy provided with the machine. The recommended operating and maintenance procedures set forth shall be followed to ensure warranty coverage is not jeopardized. Failure to comply with recommended operating and maintenance procedures may void machine warranty.

Any questions or problems relating to warranty policy or administration should be directed to Komatsu Service Center. Include the model and serial number, in-service date of the machine, and hour meter reading. **We especially draw your attention to the following safety advisors.**

This Page Intentionally Left Blank

# Safety

This publication contains special instructions that pertain to safety, operation, maintenance, and repair of the machine. Listed below are the signal words and symbols that precede these instructions and their meanings:

## DANGER

- The danger label indicates a hazardous situation which, if not avoided, will result in death or serious injury.

## WARNING

- The warning label indicates a hazardous situation which, if not avoided, could result in death or serious injury.

## CAUTION

- The caution label, used with the safety alert symbol indicates a hazardous situation which, if not avoided, could result in minor or moderate injury (includes the safety alert symbol .

## CAUTION

- The caution label (without safety alert symbol) is used to address practices not related to personal injury – only equipment damage.

## NOTICE

The NOTICE graphic is to indicate areas of importance to the reader that are not related to personal injury or machine damage.

## Safety, Warnings, and Cautions

### WARNING

#### CRUSH HAZARD

- Crush hazard exists from improperly inflated tires. Improperly inflated tires can be dangerous or hazardous when operating the machine. Check inflation pressures as required to ensure the correct pressure is present. Keep tires inflated to factory recommended pressures. Failure to keep tires properly inflated can cause crush hazards from uncontrolled machine movement resulting in serious injury or death.
- Crush hazards exist if the machine is started or moved while work processes are being performed on the machine. Place bucket flat and level on the ground. Place frame lock in the locked position and lock out the machine's starting capability before performing any work process. Follow all applicable lockout procedures and local rules and regulations for performing work processes. ANYONE performing inspections or service procedures to the machine should be familiar with ALL instructions and procedures contained in the machine's SERVICE MANUAL. Crush hazard could occur if the machine is started or moves while any type of work process is being conducted on the machine, resulting in serious injury or death.

- Crush hazards exist in machine pivot area and area between the tires. Do not enter these areas unless it is verified that the operator has control over the steering and that personnel locking the frame lock have good communication with the operator. Entering the pivot area and area between the tires while the machine is moving or pivoting (articulating) could cause crush hazards resulting in serious injury or death.
- Crush hazards exist if all personnel are not cleared from the bucket and lift arm area before using the hydraulic hoist and bucket hydraulic pressure bleed down valves to relieve pressure from the hoist and bucket circuit. Clear all personnel from the area around the bucket and lift arms before operating hydraulic hoist and bucket hydraulic pressure bleed down valves. Using the hydraulic bleed down valves could result in some movement of the lift arms and bucket which could cause a crush hazard resulting serious injury or death.

### **STRUCK BY AND CRUSH HAZARDS**

- Struck by or crush hazards exist when inflating the tire. If the tire ruptures it is possible to be crushed or struck by flying debris. It is recommended to stand behind the tread, as shown below. Do not stand in front of or behind the tire and rim assembly (DO NOT stand in front of either tire sidewall). Failure to stand behind the tread of the tire during a rupture can cause struck by or crush hazards resulting in serious injury or death.
- Struck-by or crush hazards exists when removing the tire. It is essential to follow the appropriate incremental torque pattern for removal of wheel/tire assembly from the machine. Not following this pattern could cause some fasteners to become overloaded resulting in breakage and unplanned movement of the wheel/tire assembly or component damage. Refer to the illustrations in this document (below) for appropriate torque pattern to follow. Failure to follow the correct bolt removal pattern and procedure can cause Struck-by or crush hazards resulting in serious injury or death.
- Struck-by or crush hazards exists when installing the tire and rim assembly. It is essential to follow the appropriate incremental torque pattern for installation of wheel/tire assembly on the machine. Not following this pattern could cause some fasteners to become overloaded resulting in breakage and unplanned movement of the wheel/tire assembly or component damage. Refer to the illustration “L-1350/L-1850/L-2350 wheel capscrew installation torque pattern – models 51 and 57 planetary drive” for appropriate torque pattern to follow. Failure to follow the correct bolt removal pattern and procedure can cause Struck-by or crush hazards resulting in serious injury or death.
- Struck-by or crush hazards exist when tramping without consulting tire and chain manufacturers. Consult the tire and chain manufacturer to determine tramping speeds and distances. TYPICALLY, a 5 mph (8 kmh) tramping speed is acceptable, but ultimately is determined by the tire and chain manufacturers. Failure to consult tire and chain manufacturers to determine tramping speeds and distances can result in loss of machine control because of tire damage or failure, which could cause struck-by or crush hazards resulting in serious injury or death.

### **STRUCK-BY OR STRUCK AGAINST HAZARDS**

- Struck-by or struck against hazards exist when deflating tires. Tires are under great pressure. When the pressure is released, foreign debris inside the tire or valve core can be propelled great distances, impelling a person, striking them, or knocking them against something. Do not stand in air stream when the tire is being deflated. Any foreign material inside tire can be released with air flow. Wear ear and eye protection and all other locally required Personal Protective Equipment (PPE) while deflating a tire. Failure to stay out of the air flow or wear proper PPE can cause struck-by or struck against hazards resulting in severe injury or death.

### **EXPLOSION HAZARD**

- Explosion hazard exists if heating the tire or tire rim while the tire is still mounted and inflated. This means NO welding, grinding, using a cutting or heating torch or any other procedure that would cause extreme heat. Generating heat on the rim or tire of an inflated tire can cause an explosion hazard resulting in serious injury or death.

- Explosion hazard exists when inflating tires. Always use clean air when inflating tires. Refer to text “TIRE EXPLOSION (SAFETY HINTS)”, located in “SAFETY, WARNINGS, AND CAUTIONS” in this section, regarding clean inflation air and tire explosions. Failure to use clean air when inflating tires can cause an explosion hazard resulting in serious injury or death.

#### **EYE INJURY HAZARD**

- Eye injury hazard exists when inflating or deflating tires. Debris can be propelled by escaping air with enough force to permanently injure eyes. If deflating a tire, stand clear and ensure all personnel in the area are clear of the area if the air is released to atmosphere. ALWAYS wear safety glasses and appropriate personal protective equipment (PPE), as required locally, when inflating or deflating tires. Failure to wear safety glasses and appropriate PPE can result in eye damage resulting in injury.

#### **EXPLOSION AND FIRE HAZARDS**

- Explosion or fire hazards exist if using combustible detergents to clean rim parts or tire sections. Fire or explosion can occur if flammable fumes build up inside tire. Use only non-combustible fluids to clean the tire or rim. Using combustible detergents to clean rim parts or tire sections can cause explosion or fire hazards resulting in serious injury or death.

This Page Intentionally Left Blank

## Tire Explosion (Safety Hints)

In the past few years, there have been instances of tires exploding violently while on vehicles. The tires were literally torn apart by the forces of violent explosions. When tires explode in this manner, the forces involved are so great that the potential for serious personal injury or property damage exists.

The purpose of this document is to remind all tire service people that more explosions are going to occur if the proper precautions are not taken.

As you probably have read before, the cause of these explosions is the existence of vapors inside the casing that form an explosive mixture with air. These vapors may enter the casing in several ways, as explained below. Such mixtures, under the right conditions, may be ignited by an electro-static discharge.

It is believed, that in most cases, flammable vapors are pumped into the tire along with the air from the air compressor when the tire is inflated.

There are various ways that flammable vapors can get into the compressor:

- USING ALCOHOL, METHANOL, DRY GAS, AND OR ANY OTHER FLAMMABLE MATERIAL IN THE COMPRESSOR TO PREVENT FREEZING OR CONDENSATION - This is a sure way of pumping in explosive vapors and should not be done. Proper and frequent draining of moisture condensation from the compressor tank should eliminate the need for antifreeze. It is strongly recommended that the compressor be located inside where freezing will not be a problem.
- STORING FLAMMABLE SOLVENTS OR RUBBER CEMENTS IN PROXIMITY OF THE AIR INTAKE OF THE COMPRESSOR - It is recommended that the compressor be isolated in an area by itself and kept completely free from other operations such as tire repairing, studding, etc.
- CLEANING OF THE AIR SCREEN ON THE COMPRESSOR INTAKE WITH FLAMMABLE SOLVENTS SUCH AS GASOLINE OR VARSOL - When cleaning, be doubly sure the entrapped solvent on the screen is well blown off with an air hose before reinstalling.
- LOCATION OF A BATTERY CHARGER NEAR THE AIR COMPRESSOR INTAKE - When a battery is being recharged, it gives off hydrogen gas that is highly flammable. This could be very dangerous if sucked into the compressor intake.

Also, one other source of flammable vapor could be the bead lubricant you are using. Check to make sure that this does not have a flammable base.

We strongly advise that you take a fresh look at your tire inflation and compressor equipment and make sure that all potential sources of trapping flammable vapors in a tire are eliminated.

### ***Reprinted Courtesy of the UNIROYAL Tire Company — Detroit, Michigan***

Explosions of air inflated tires have resulted from heat-induced gas combustion inside the tires. Explosions can be caused by heat that is generated by welding, by heating rim components, or by external fire. A tire explosion is more violent than a simple blowout. The explosion can propel the tire or the rim components long distances. Do not approach a warm tire. Maintain a minimum distance until the tire has cooled. Both the force of the explosion and the flying debris can cause property damage, personal injury, or death.

Servicing tires and rims can be dangerous. Carefully obey the specific instructions from the tire manufacturer. Only trained personnel using proper tools and proper procedures should perform any maintenance procedure. Tire explosions are possible if correct procedures are not used for servicing tires and rims. Failure to follow proper procedures can cause serious personal injury or death.

A rim inspection program for crack testing and component inspection is a good idea for helping to prevent tire explosions.

This Page Intentionally Left Blank

# General Introduction

## Inspect the Work Area

The area, in which the machine works, should be inspected frequently for hazards that could damage tires. Although it takes time and effort to maintain the work area properly, the delay and cost of tire and machine breakdowns caused by a poorly maintained work area is many times greater.

## Inspect the Tires

All tires should be inspected daily for inflation pressure, cuts, bruises, fabric breaks, excessive or uneven wear, embedded rocks, and any other damage that can be repaired or corrected. A considerable increase in tire service can be realized if tire injuries are repaired before they have progressed to the non-repairable stage. Tires should be kept inflated to the correct air pressure at all times (refer to "Tire Inflation and Deflation Procedures", located within this section).

## NOTICE

**Tire damage may be hidden under dirt and mud. It is IMPORTANT to periodically clean the tires with a hot water high-pressure washer and do a thorough inspection of the tires.**

## Prevent Tire Contact with Oil and Petroleum Products

Rubber that is exposed to oil, gasoline, or grease for prolonged periods of time may become spongy and deteriorate rapidly. Always avoid driving a machine equipped with rubber tires through a puddle of gasoline, fuel oil, lubricating oil, or grease. Never let a tire stand overnight in oil or grease.

## Prevent Overloading

P&H wheel loaders are designed to carry a maximum payload. Excessive loading will overstress both the machine and tires and shorten the life of both. Verify the payload for the model of machine before operation.

This Page Intentionally Left Blank

# Theory of Operation

Tire sizes and inflation pressures are calculated for specific machine models and the loads they are expected to experience. The correct size tire, properly inflated, is critical to the designed performance of the machine.

## WARNING

**Crush hazard exists from improperly inflated tires. Improperly inflated tires can be dangerous or hazardous when operating the machine. Check inflation pressures as required to ensure the correct pressure is present. Keep tires inflated to factory recommended pressures. Failure to keep tires properly inflated can cause crush hazards from uncontrolled machine movement resulting in serious injury or death.**

## WARNING

**Eye injury hazard exists when inflating or deflating tires. Debris can be propelled by escaping air with enough force to permanently injure eyes. If deflating a tire, stand clear and ensure all personnel in the area are clear of the area if the air is released to atmosphere. ALWAYS wear safety glasses and appropriate personal protective equipment (PPE), as required locally, when inflating or deflating tires. Failure to wear safety glasses and appropriate PPE can result in eye damage resulting in injury.**

## NOTICE

- Properly inflated tires provide optimum performance.
- Over inflated tires can bounce the machine or load, (putting undue stresses on the machine frame) and can cause motor overspeed.
- Under inflated tires can have sluggish response times as well as providing inadequate support for the applied load.
- Improperly inflated tires can be dangerous or hazardous when operating the machine.
- NEVER operate the machine with under-inflated or over-inflated tires.
- Bleeding the tire should never counteract excessive pressure buildup. The only correct way to reduce excessive buildup is to reduce load, speed or both.
- Have cuts or punctures in tires repaired before adding air.
- Do not stand in air stream. Any foreign material inside tire will be released with air flow. Injury is possible if struck by object propelled by the escaping air.
- Refer to TIRE EXPLOSION (SAFETY HINTS) publication, located within this section, regarding clean inflation air and tire explosions.

Tire operation is limited by various factors such as:

- Load weight
- Speed of machine
- Distances traveled
- Time

These factors and possibly others are used to develop guidelines used to help prevent damage to tires being exposed to these factors. The guidelines are commonly referred to as Trimming Guidelines.

## Tramming Guidelines

Speed restrictions (Tramming Guidelines) should be determined in consultation with the tire and chain application manufacturer. Failure to consult with the tire manufacturer regarding your specific tire and application can result in severe tire damage or tire failure.

 **WARNING**

**Struck-by or crush hazards exist when tramming without consulting tire and chain manufacturers. Consult the tire and chain manufacturer to determine tramming speeds and distances. TYPICALLY, a 5 mph (8 kmh) tramming speed is acceptable, but ultimately is determined by the tire and chain manufacturers. Failure to consult tire and chain manufacturers to determine tramming speeds and distances can result in loss of machine control because of tire damage or failure, which could cause struck-by or crush hazards resulting in serious injury or death.**

# Component Description

Proper tire inflation plays a key role in maximizing both tire life and overall machine performance. While rubber-tired machines have numerous advantages over their track-mounted counterparts, proper care of their tires is essential to maintaining those advantages.

## Tires

Tires of various sizes are matched to specific models. The following chart provides details for specific models.

Machine	L-1350	L-1850	L-2350
Tire Size/Ply Rating	50/80 x 57, 68 PR	58/85 X 57, 84 PR	70/70 X 57, 84 PR
Rim Size	36x57	47 x 57	60 x 57

**Table 1. Tire and rim sizes (TYPICAL)**

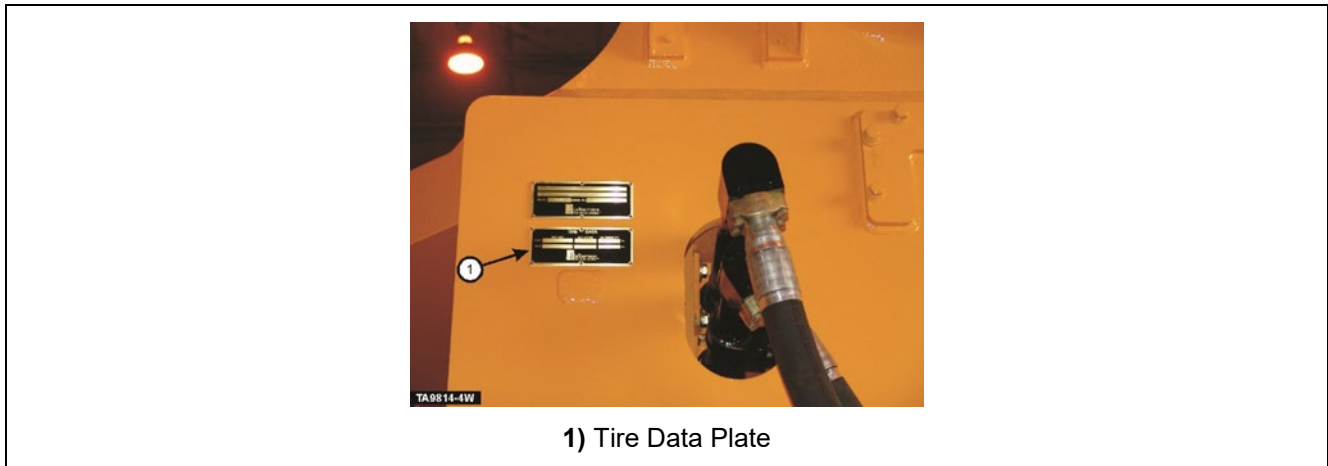

**Figure 1. Tire data plate located on the right side of the front frame**

### Tire Inflation/Deflation Valve with Inflator

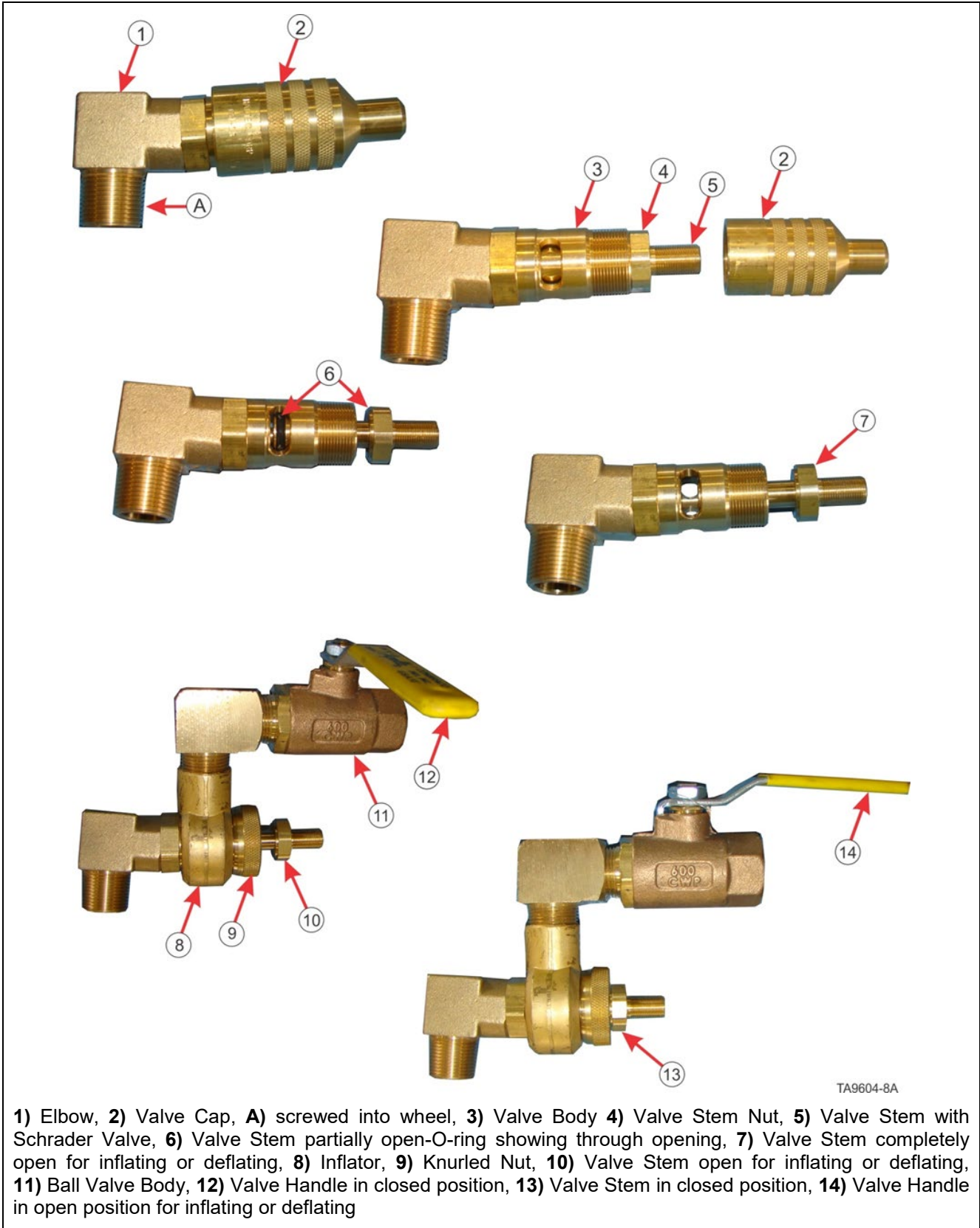

TA9604-8A

1) Elbow, 2) Valve Cap, A) screwed into wheel, 3) Valve Body 4) Valve Stem Nut, 5) Valve Stem with Schrader Valve, 6) Valve Stem partially open-O-ring showing through opening, 7) Valve Stem completely open for inflating or deflating, 8) Inflator, 9) Knurled Nut, 10) Valve Stem open for inflating or deflating, 11) Ball Valve Body, 12) Valve Handle in closed position, 13) Valve Stem in closed position, 14) Valve Handle in open position for inflating or deflating

Figure 2. Tire valve and inflator components

# Circuit Description

The tires are mounted onto the wheel rims that are mounted onto the planetary drives. The planetary drives are mounted to and powered by electric motors.

## Settings and Adjustments

### Tire Inflation and Deflation Procedures

#### Machine without Chains Tire Pressure

	L-1350	L-1850	L-2350
Tire Size/Ply Rating	50/80 x 57, 68 PR 52/80 x 57, 68 PR L4 tread	58/85 x 57, 84 PR	70/70 X 57, 84 PR
Inflation Pressure, Front (psi)	105 psi (7.2 bar)	110 psi (7.58 bar)	105 to 110 psi (7.24-7.58 bar)
Inflation Pressure, Rear (psi)	55 psi (3.79 bar)	55 psi (3.79 bar)	70 to 75 psi (4.82-5.17 bar)
Rim Size	36 x 57	47 x 57	

#### Machine with Chains Tire Pressure

	L-1350	L-1850	L-2350
Tire Size/Ply Rating	50/80 x 57, 68 PR 52/80 x 57, 68 PR L4 tread	58/85 x 57, 84 PR	70/70 X 57, 84 PR
Inflation Pressure, Front (psi)			110 to 115 psi (7.58-7.92 bar)
Inflation Pressure, Rear (psi)			85 to 90 psi
Rim Size			

## NOTICE

The inflation pressures in the previous table are based on latest information from the tire manufacturers and should be applicable for the majority of locations. However, it is possible that local conditions could require a variation in the recommended pressures. It is possible that a tire manufacturer might issue an official Technical Bulletin regarding a tire pressure deviation from the table, the user should provide the tire manufacturer recommendation to Wheel Loader Product Support before changing the recommended tire pressure. Failure to consult with the tire manufacturer and Komatsu regarding specific tire pressure and application can result in severe tire damage or tire failure and may possibly affect machine warranty.

Recommended inflation pressures are “cold” pressures. If pressure is checked before the tire cools down (in some cases this can be up to 24 hours) allow a margin of 15 psi (1 bar) over recommended “cold” pressure for pressure build up due to heat.

To maintain these pressures, weekly inspections should be instituted to verify cold inflation pressures. When possible, daily checks by the operators will help to maintain optimum pressure levels, lengthen tire life and increase machine performance.

The Tire Data Plate located on the right side of the front frame shows the proper tire pressures.

**Table 2. Tire size and inflation data - recommended cold tire inflation pressures**

## ⚠ WARNING

**Explosion and struck by hazards exist if the tire is inflated before mounting it on the machine. Install the tire and wheel assembly on the machine before inflating the tire. Failure to mount the tire and wheel assembly onto the machine before inflating the tire can cause explosion or struck by hazards resulting in severe injury or death.**

Over-inflation and under-inflation tire pressures can cause serious tire and machine problems.

Of particular significance is over-inflation of the rear tires. This condition can have a very detrimental effect on frame fatigue and traction motor overspeed. Over-inflated rear tires can also cause the rear of the machine to “bounce”. This action, in turn, multiplies any stresses through the rear frame and the articulation ball/sockets. Under severe instances, the rear tires can lose traction and cause an instantaneous motor overspeed.

<b>Improper Inflation Hazards</b>	
<b>Over Inflation</b>	<b>Under Inflation</b>
Increased Risk of Cutting	Increased Risk of Sidewall Damage
Increased Wear Rate	Increased Wear Rate
Stiff Ride	Poor Stability
Reduced Tractive Effort	Potential Rim Slippage
Increased Shock Load	Increased Risk of Casing Fatigue
Potential Overspeed	
Increased Frame Stress	

## ⚠ WARNING

**Struck by or crush hazards exist when inflating the tire. If the tire ruptures it is possible to be crushed or struck by flying debris. It is recommended to stand behind the tread, as shown below. Do not stand in front of or behind the tire and rim assembly (DO NOT stand in front of either tire sidewall). Failure to stand behind the tread of the tire during a rupture can cause struck by or crush hazards resulting in serious injury or death.**



TA10966

## NOTICE

- **NEVER** operate the machine with under-inflated or over-inflated tires.
- **Always**, repair all cuts and punctures before adding air.
- **Bleeding the tire should never counteract excessive pressure buildup. The only correct way to reduce excessive buildup is to reduce load, speed or both.**

## ⚠ WARNING

Eye injury hazard exists when inflating or deflating tires. Debris can be propelled by escaping air with enough force to permanently injure eyes. If deflating a tire, stand clear and ensure all personnel in the area are clear of the area if the air is released to atmosphere. **ALWAYS** wear safety glasses and appropriate personal protective equipment, as required locally, when inflating or deflating tires. Failure to wear safety glasses can result in eye damage resulting in injury.

## Valve System

The wheels on the machines are equipped with a valve system, which provides inflation and deflation of the tires (refer to "Tire Valve"). The following instructions are for inflating and deflating the tires using the Haltec Mega Bore Valve System. If another system is optionally installed, refer to that manufacturer's instructions for use of the valve system.

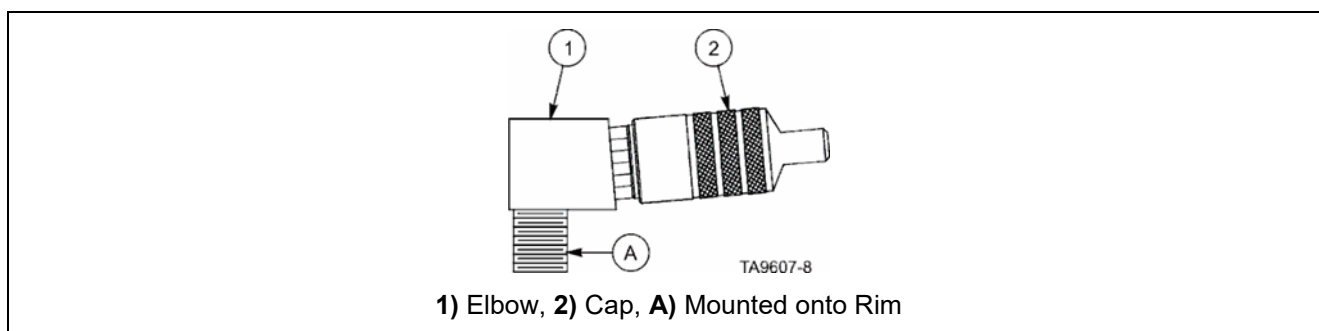

**Figure 3. Tire valve**

## Inflation Equipment

A 100-CFM air compressor must be utilized to get maximum benefit of the valve system. This air compressor then needs to be connected to the inflator with hoses and couplers that have a minimum inside diameter of 11/16" (18.84 mm).

## NOTICE

**If anything less than these requirements is used, the system will not work to its full potential.**

## Inflating and Deflating Tires

### Safety Preparations

Use the following procedure to isolate energy sources before performing any removal, replacement, or installation procedures described in this document.

#### **WARNING**

Crush hazards exist if the machine is started or moved while work processes are being performed on the machine. Place bucket flat and level on the ground. Place frame lock in the locked position and lock out the machine's starting capability before performing any work process. Follow all applicable lockout procedures and local rules and regulations for performing work processes. ANYONE performing inspections or service procedures to the machine should be familiar with ALL instructions and procedures contained in the machine's SERVICE MANUAL. Crush hazard could occur if the machine is started or moves while any type of work process is being conducted on the machine, resulting in serious injury or death.

- a. Stop the wheel loader on flat level ground.
- b. Move the frame lock to the locked position so that the frame cannot be steered.
- c. Place wheel chocks in front and behind each wheel.

#### **WARNING**

Crush hazards exist in machine pivot area and area between the tires. Do not enter these areas unless it is verified that the operator has control over the steering and that personnel locking the frame lock have good communication with the operator. Entering the pivot area and area between the tires while the machine is moving or pivoting (articulating) could cause crush hazards resulting in serious injury or death.

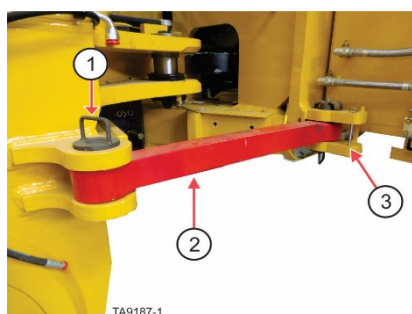

- 1) Retaining pin for locked position, 2) Frame lock - shown in locked position,  
3) Retaining pin bracket for un-locked position

**Figure 4. Frame lock in locked position**

- d. Set bucket flat and level on the ground.
- e. Set the parking brakes.
- f. Shut off the engine.
- g. Turn the battery and engine isolation switches to the off position and install locks on the battery isolation switch.



Figure 5. Battery Isolation Box – Battery isolation switch in OFF position with locks in place

## Inflating

### NOTICE

Wheel must be mounted on the machine before inflating.

Remove rim bolt-on guard for access to valve

Clean away dirt and mud from around valve.

### NOTICE

For clarity reasons, valve is not shown installed in rim. Assume for these instructions elbow is installed into rim.

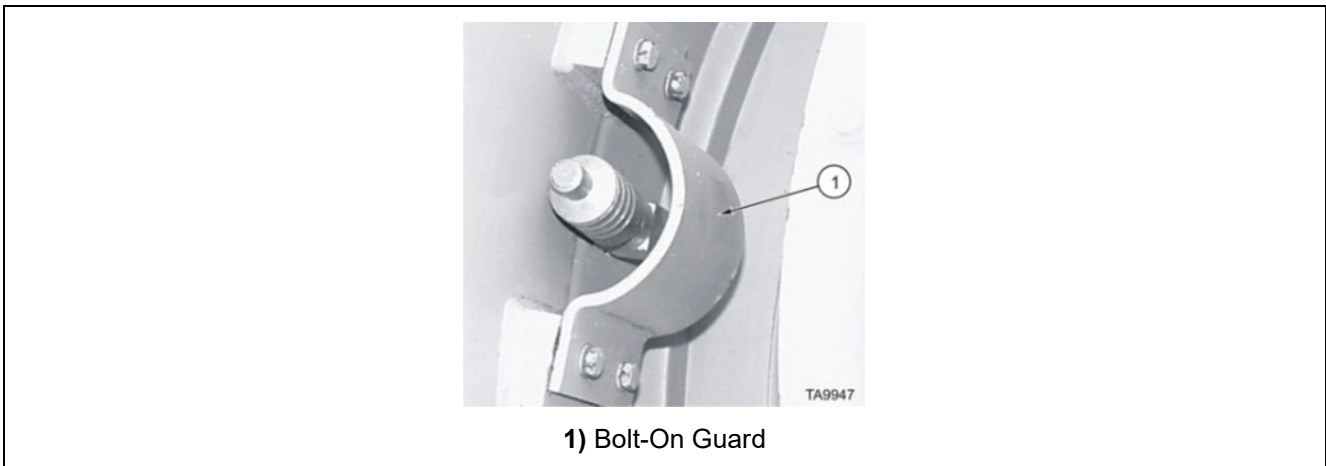
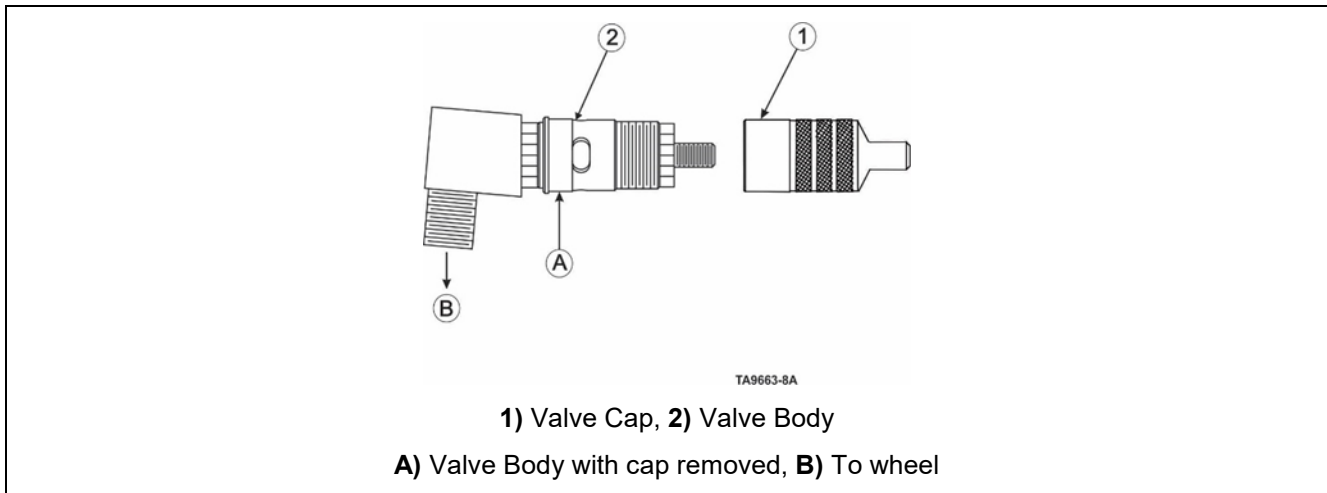

Figure 6. Tire inflation instruction illustrations

h. Remove the valve cap from the valve body.



**Figure 7. Tire inflation instructions**

- i. Assemble the inflator components.
  - The inflator assembly is provided with the inflator body, shut off valve (ball type) an elbow fitting (11/16" min. diameter).
- j. Install a male quick coupling (customer furnished) into the end of the shutoff valve as shown.
- k. Assemble the pieces as shown below.
  - Use thread sealant on all threads.

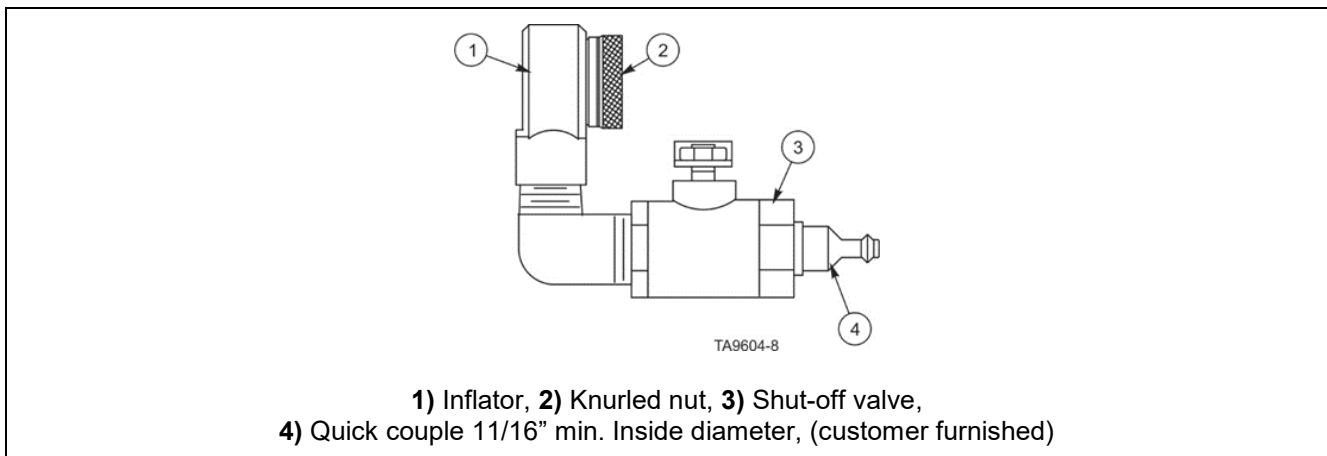

**Figure 8. Tire inflation instruction illustrations**

- l. Couple the body with the inflator by turning the knurled nut on the inflator in a clockwise direction until seated.
- m. Place shut off valve in the closed position as shown (A).

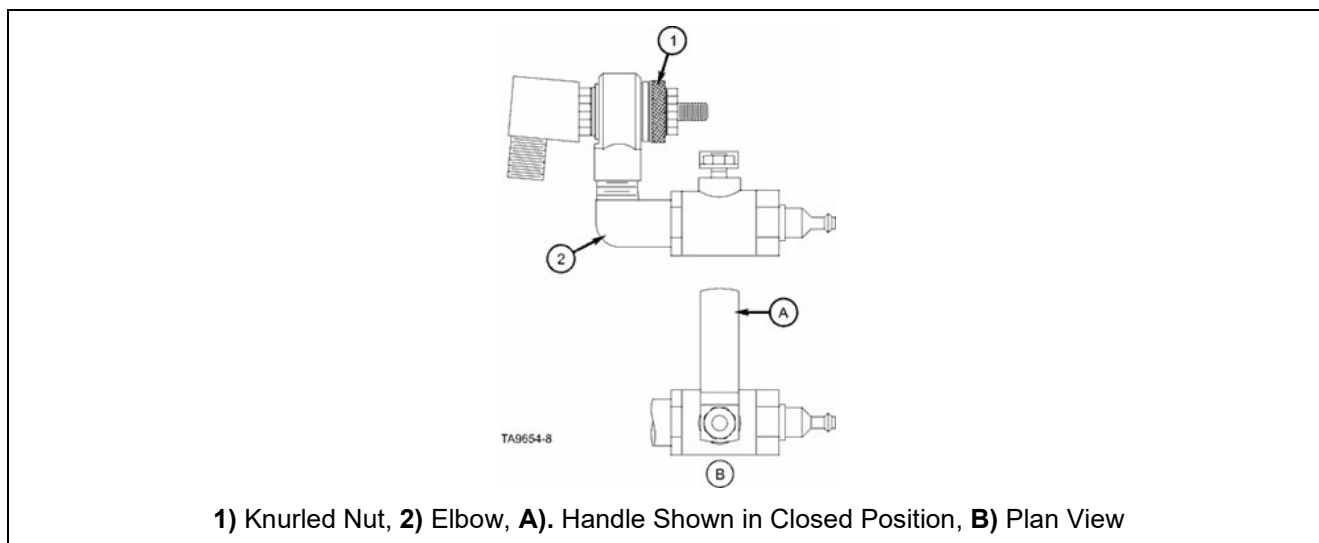

**Figure 9. Tire inflation instruction illustrations**

- n. Turn the valve stem nut counter-clockwise until it reaches the internal stop and will turn no farther. There may be a small amount of air escaping as the valve stem nut is being unscrewed.
- The tire is now ready to be inflated.

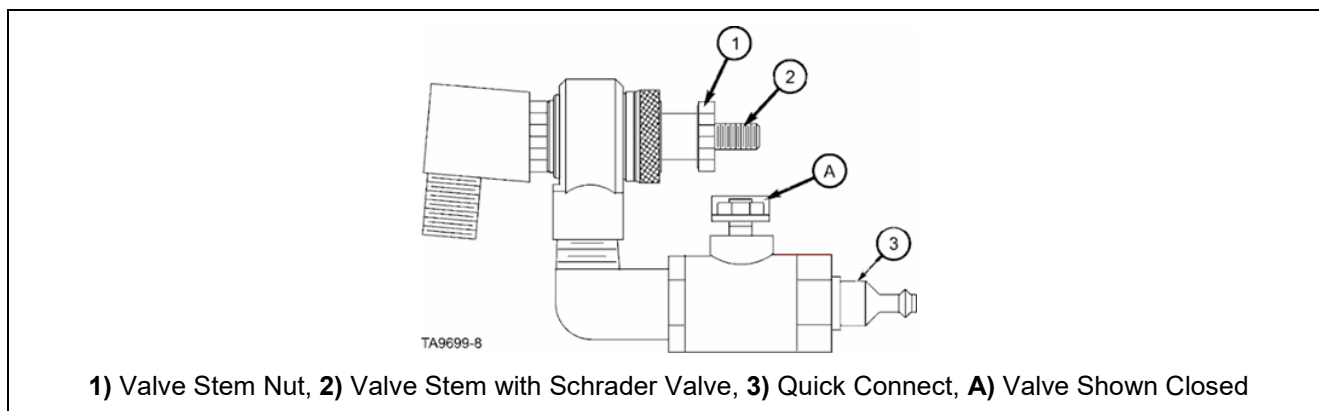

**Figure 10. Tire inflation instruction illustrations**

## NOTICE

Refer to Tire size and inflation data in the Tire Size Inflation Data Recommended Cold Tire Inflation Pressures Table, within this section, for the proper tire pressure. The tire inflation data is also located on a metal plated mounted on the right-hand side of the front frame at the pivot area (refer to “Tire data plate located on the right side of the front frame”). The front and rear tires have different pressures.

- o. Couple air hose to male quick connector. Make sure the air pressure available to the inflator is at 100 psi (6.9 bar).
- p. Slowly open the ball valve, connected to the inflator and air compressor, to inflate the tire.

## ⚠ WARNING

Explosion and struck-by hazards exist when inflating tires. Tires can explode, sending debris through the air with great force. **DO NOT** over inflate the tire. Inflate the tire to the factory recommended pressure. Failure to inflate the tire to the proper pressure can cause an explosion or struck-by hazard resulting in severe injury or death.

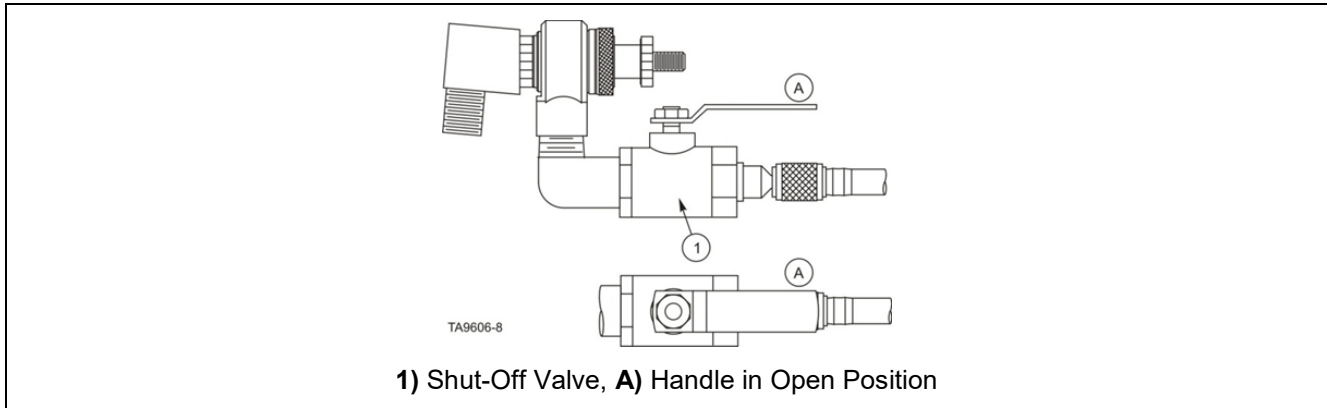

**Figure 11. Tire inflation instruction illustrations**

- q. Periodically, close the shut-off valve.
  - Check air pressure with an air pressure gauge, through the Schrader valve, located in the valve stem.
  - If air pressure has not risen to the desired point, open the shut-off valve.
- r. Retest pressure periodically.
- s. Continue this procedure until tire is at proper inflation pressure.
- t. Turn the shut-off valve to the closed position and remove the air hose when inflation is complete.
- u. Turn the Valve Stem Nut clockwise until it is tightened back against the face of the valve body.
  - There may be a small amount of air escaping while the valve stem is being screwed back into place.

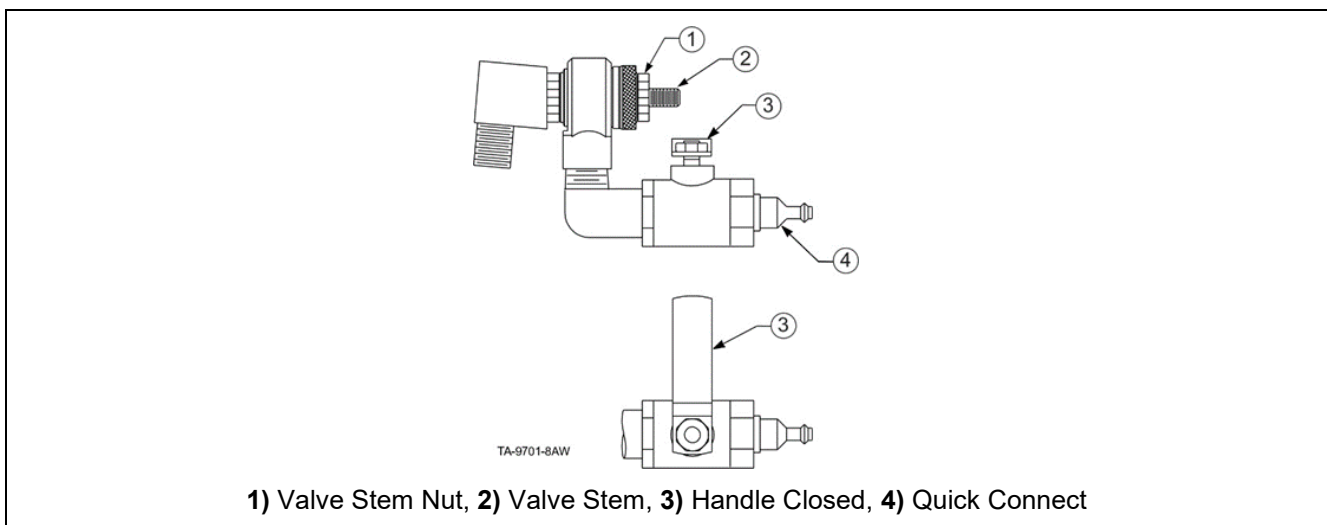

**Figure 12. Tire inflation instruction illustrations**

- v. Remove the inflator assembly from the valve body by turning the knurled nut on the inflator in a counterclockwise direction to disengage, as shown.

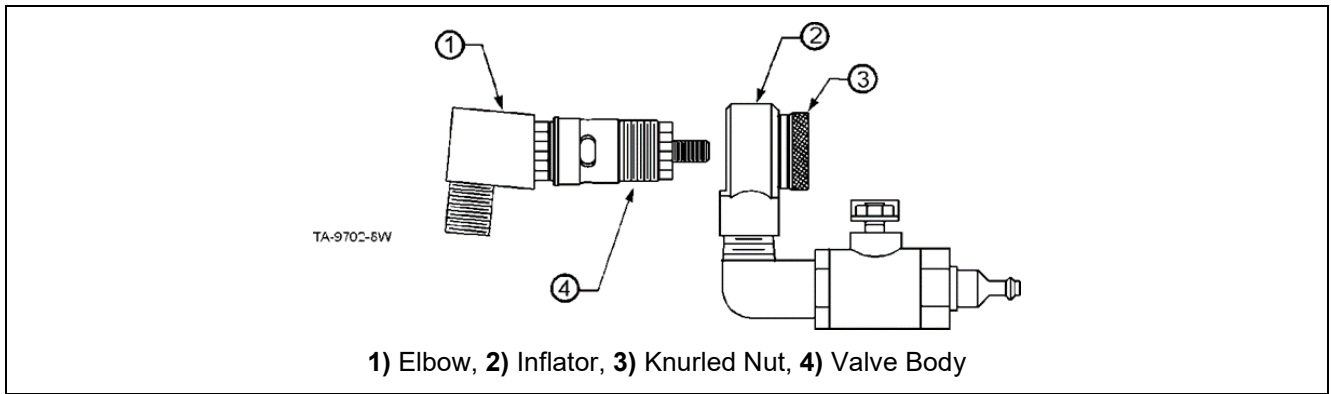

Figure 13. Tire inflation instruction illustrations

- w. Replace the valve cap.
- x. Replace the bolt-on cover.

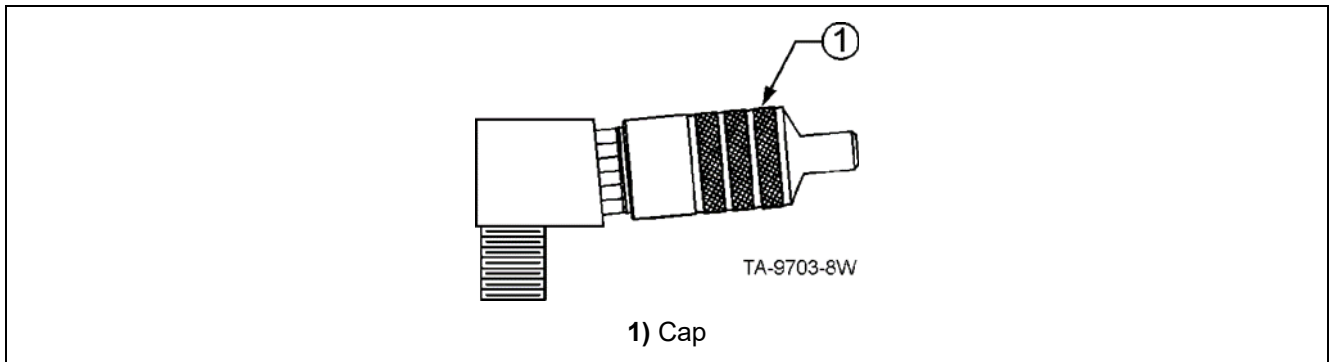

Figure 14. Tire inflation instruction illustrations

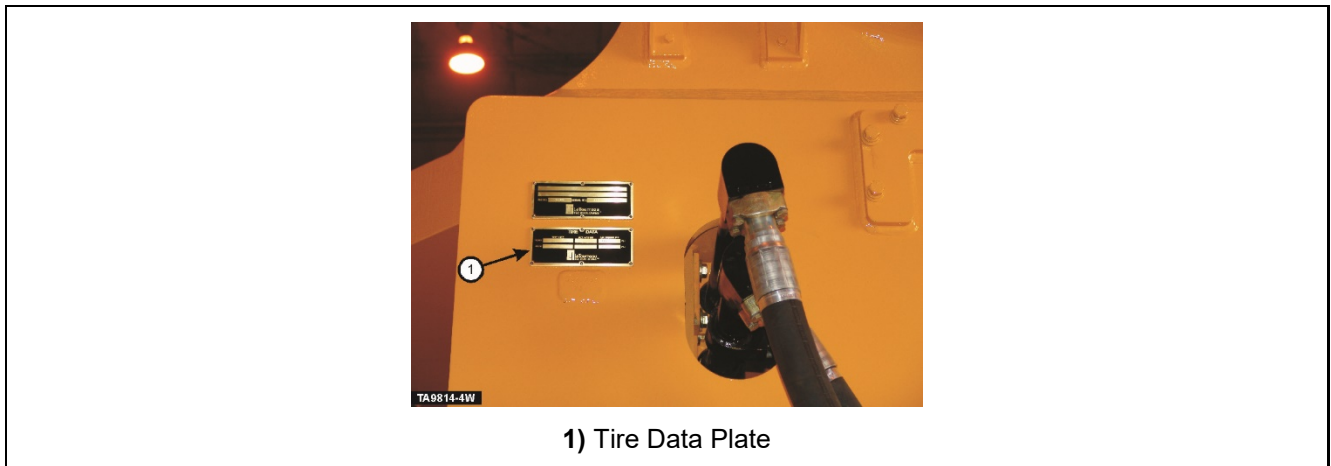

Figure 15. Tire Data Plate Located on the Right Side of the Frame

## Deflating

### WARNING

Struck-by or struck against hazards exist when deflating tires. Tires are under great pressure. When the pressure is released, foreign debris inside the tire or valve core can be propelled great distances, impelling a person, striking them, or knocking them against something. Do not stand in air stream when the tire is being deflated. Any foreign material inside tire can be released with air flow. Wear ear and eye protection and all other locally required Personal Protective Equipment (PPE) while deflating a tire. Failure to stay out of the air flow or wear proper PPE can cause struck-by or struck against hazards resulting in severe injury or death.

### NOTICE

Before deflating tire, the loader must be jacked up or hoisted so that tire is clear of the ground. Refer to **JACKING INSTRUCTIONS**, located in Section 03 “STRUCTURAL” of the Service Manual.

- a. Remove the valve cap from the valve body.

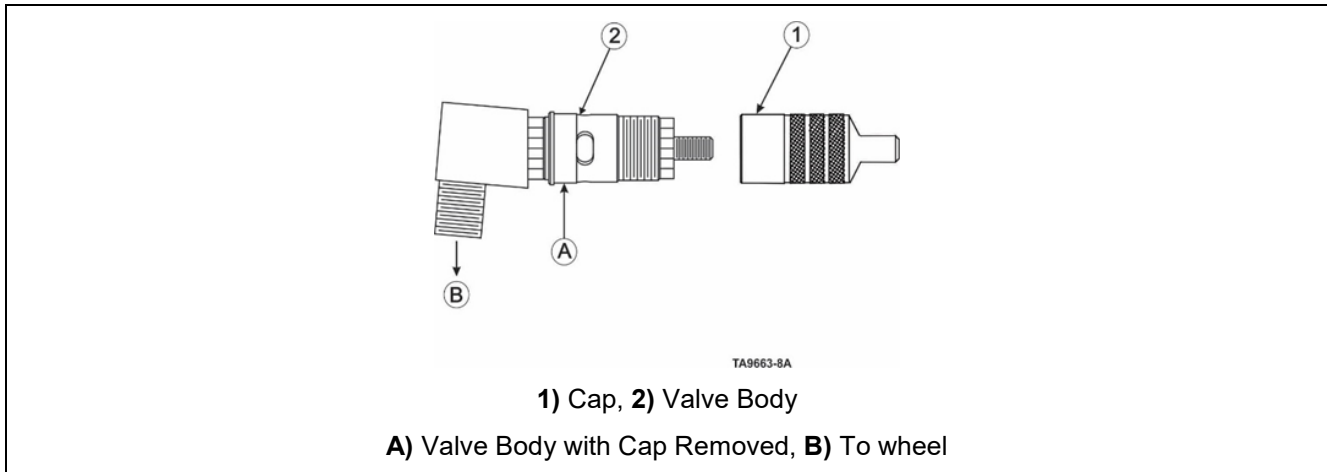

**Figure 16. Tire deflation instructions**

- b. Assemble the inflator components.
- The inflator assembly is provided with the inflator body, shut off valve (ball type), and an elbow fitting (11/16" min. diameter).
- c. Install a male quick coupling (customer furnished) into the end of the shutoff valve as shown.

- d. Assemble the pieces as shown below.
- Use thread sealant on all threads.

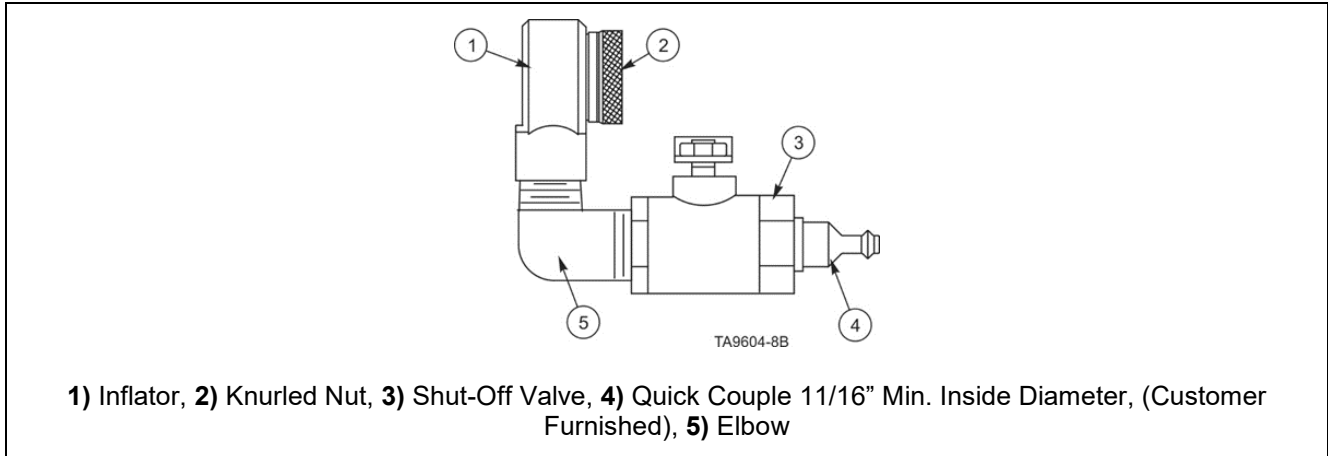

**Figure 17. Tire deflation instruction illustrations**

- e. Couple the valve body with the inflator by turning the knurled nut on the inflator in a clockwise direction until seated.
- f. Place shut off valve in the closed position as shown.

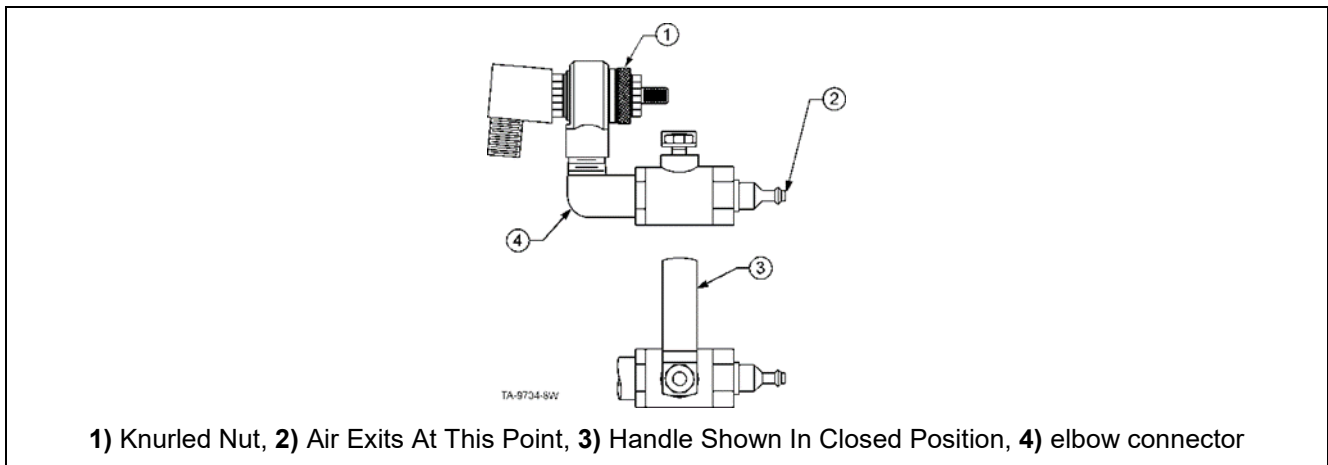

**Figure 18. Tire deflation instruction illustrations**

- g. Turn the valve stem nut counter-clockwise until it reaches the internal stop and will not unscrew any more.
- There may be a small amount of air escaping as the valve body is being unscrewed.
  - The tire is now ready to be deflated.

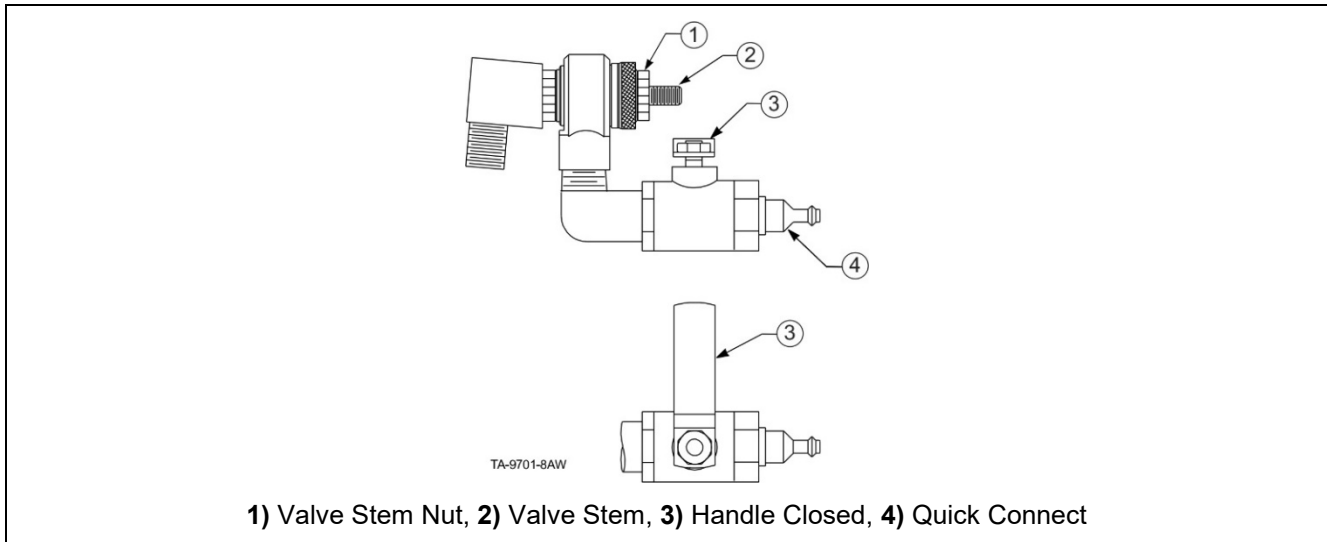

Figure 19. Tire deflation instruction illustrations

- h. Deflate tire by opening the ball valve connected to the inflator.

## WARNING

Struck-by hazard exists when deflating tires. When the sound of escaping air stops, always remove the Schrader valve and run a wire through the stem to be sure the air is completely evacuated, before performing any service work on the tire and rim assembly. It is possible for foreign debris to plug the valve stem, preventing the tire from deflating completely. Failure to confirm the valve stem is not restricted can cause struck-by hazards resulting in severe injury or death.

## WARNING

Eye injury hazard exists when inflating or deflating tires. Debris can be propelled by escaping air with enough force to permanently injure eyes. If deflating a tire, stand clear and ensure all personnel in the area are clear of the area if the air is released to atmosphere. ALWAYS wear safety glasses and appropriate personal protective equipment, as required locally, when inflating or deflating tires. Failure to wear safety glasses can result in eye damage resulting in injury.

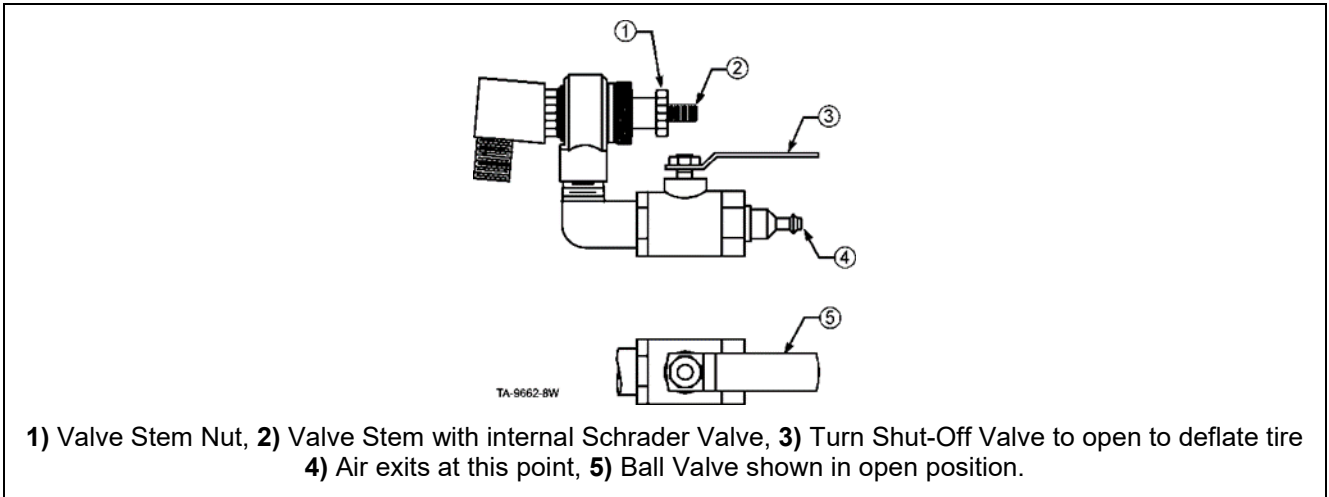

Figure 20. Deflation instruction illustrations

- i. Remove the inflator from the valve body by turning the knurled nut on the inflator in a counterclockwise direction.

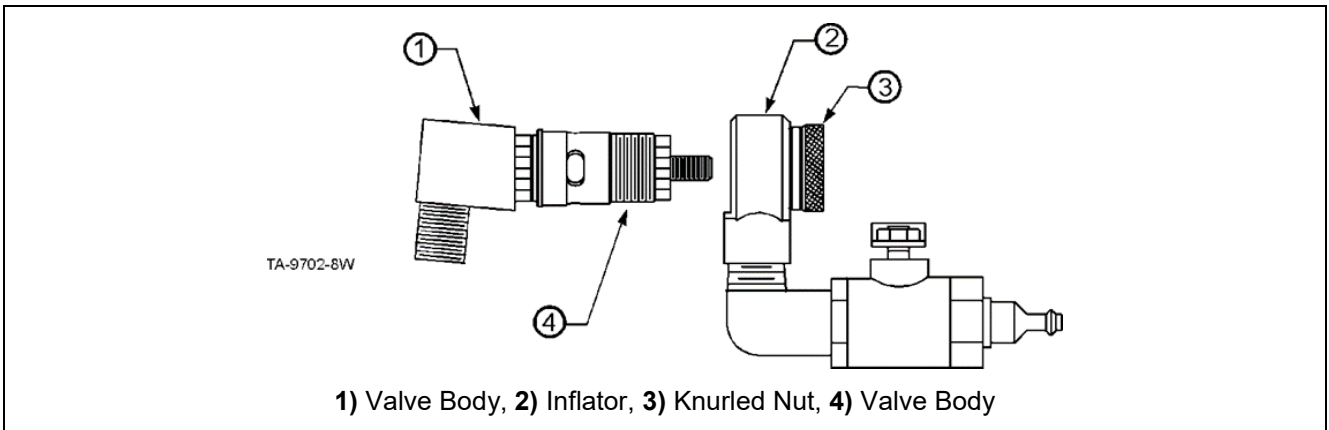

Figure 21. Tire deflation instruction illustrations

- j. Replace the Valve Cap.

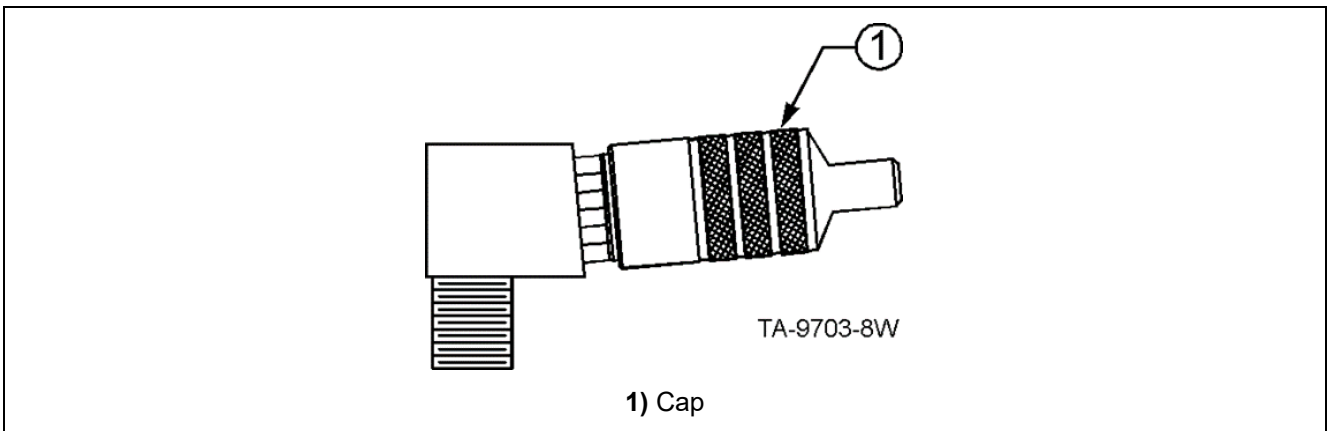

Figure 22. Tire deflation instruction illustrations

- k. Replace the bolt-on cover.

This Page Intentionally Left Blank

# Removal and Installation

## Wheel and Tire Removal

A mechanical tire handler (or crane for alternative method) of suitable capacity to hoist the wheel and tire from the loader is required. ALWAYS ALLOW A SAFETY MARGIN ABOVE THE LISTED WEIGHT. The approximate weight of the wheel and tire assemblies on a P&H wheel loader is:

- **L-1350** – 16,000 Lbs. (7303 kgs.)
- **L-1850** – 17,000 Lbs. (7711 kgs.)
- **L-2350** – 22,000 Lbs. (9979 kgs.)

## NOTICE

**NO missing or loose wheel or planetary drive capscrews are allowed when operating or moving the machine.**

## NOTICE

**When removing or installing the capscrews for: rim to planetary drive, or planetary drive to axle, the following guidelines should be followed. The capscrews should:**

- **NOT be thrown on the ground or onto other capscrews during removal. This will damage or contaminate the threads.**
- **HAVE the threads thoroughly cleaned prior to installation.**
- **HAVE the threads and shoulder lubricated with engine oil prior to installation.**
- **BE started by hand to ensure proper thread engagement – prior to using air impact.**
  - **All must be hand started prior to tightening.**
  - **Do not tighten any prior to installation of all.**
- **BE torqued per the torque chart.**
- **BE re-torqued per the intervals in the PM schedules in the Service manual.**
- **BE torqued per the correct pattern as shown in the Service manual.**

## Safety Preparations

Use the following procedure to isolate energy sources before performing any removal, replacement, or installation procedures described in this document.

## WARNING

**Crush hazards exist if the machine is started or moved while work processes are being performed on the machine. Place bucket flat and level on the ground. Place frame lock in the locked position and lock out the machine's starting capability before performing any work process. Follow all applicable lockout procedures and local rules and regulations for performing work processes. ANYONE performing inspections or service procedures to the machine should be familiar with ALL instructions and procedures contained in the machine's SERVICE MANUAL. Crush hazard could occur if the machine is started or moves while any type of work process is being conducted on the machine, resulting in serious injury or death.**

- a. Stop the wheel loader on flat level ground.
- b. Move the frame lock to the locked position so that the frame cannot be steered.

## ⚠ WARNING

Crush hazards exist in machine pivot area and area between the tires. Do not enter these areas unless it is verified that the operator has control over the steering and that personnel locking the frame lock have good communication with the operator. Entering the pivot area and area between the tires while the machine is moving or pivoting (articulating) could cause crush hazards resulting in serious injury or death.

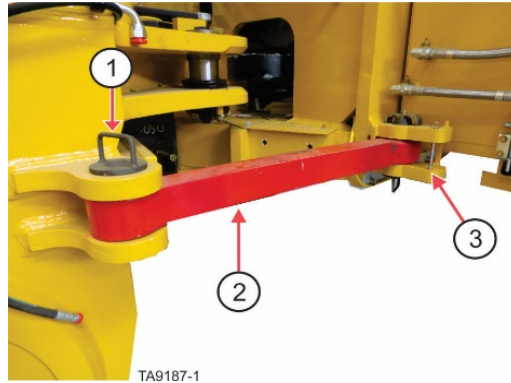

- 1) Retaining pin for locked position, 2) Frame lock - shown in locked position,
- 3) Retaining pin bracket for un-locked position

### Frame lock in locked position

- c. Set bucket flat and level on the ground.
- d. Set the parking brakes.
- e. Shut off the engine.
- f. Place wheel chocks in front and behind each wheel.
- g. Turn the battery and engine isolation switches to the off position and install locks on the battery isolation switch.



**Figure 23. Battery Isolation Box – Battery isolation switch in OFF position with locks in place**

- h. Release the air from the hydraulic reservoir by using the hydraulic reservoir air valve (ball valve) on top of the reservoir. The supply line from main air system will be blocked and reservoir air will vent out the hose that runs down the outside of the hydraulic reservoir.
  - Turn the handle to the up position as shown.

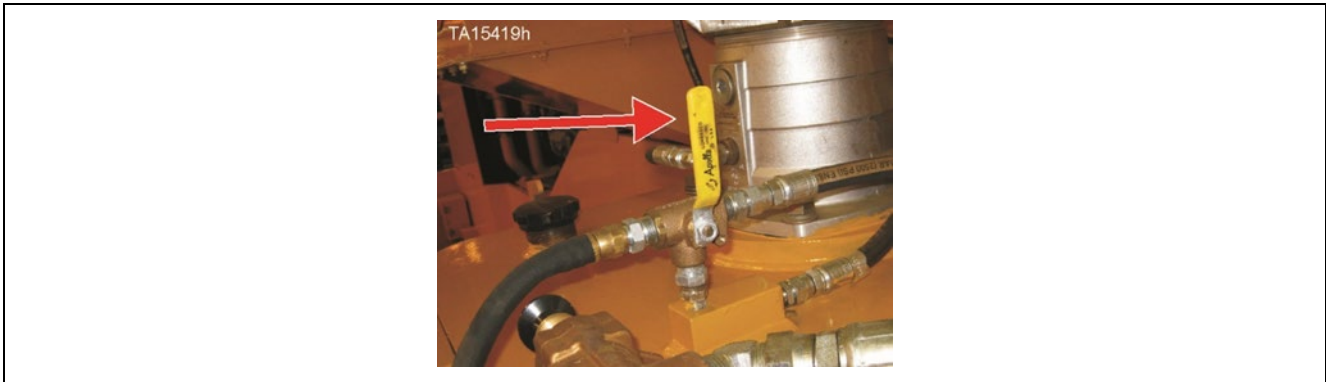

**Figure 24. Hydraulic reservoir air valve handle UP**

- i. Release the air from the various air storage reservoirs by opening all of the air bleed valves.

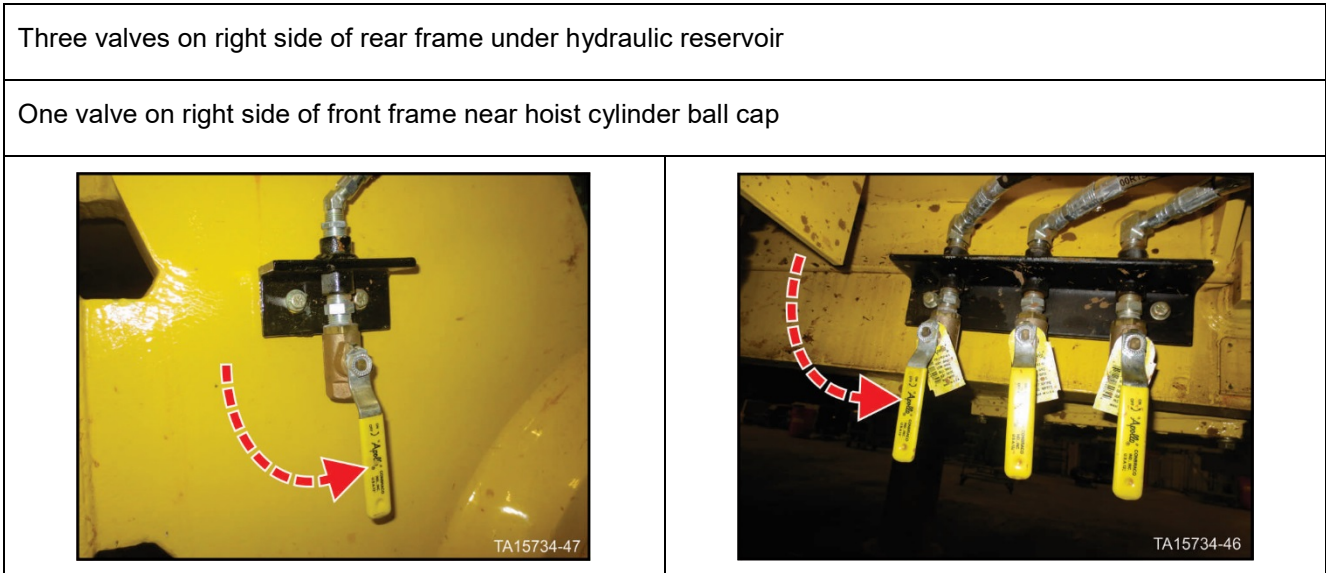

**Figure 25. Open air reservoir bleed valves**

## ⚠ WARNING

**Crush hazards exist if all personnel are not cleared from the bucket and lift arm area before using the hydraulic hoist and bucket hydraulic pressure bleed down valves to relieve pressure from the hoist and bucket circuit. Clear all personnel from the area around the bucket and lift arms before operating hydraulic hoist and bucket hydraulic pressure bleed down valves. Using the hydraulic bleed down valves could result in some movement of the lift arms and bucket which could cause a crush hazard resulting serious injury or death.**

- j. Use the hydraulic pressure bleed down valves located in the front frame underneath the Husco valves to bleed any stored pressure in the hoist and bucket cylinders.

- k. Turn each valve slowly counterclockwise as shown below and allow the pressure to bleed down.
- Open the valve completely and leave it open during this procedure.

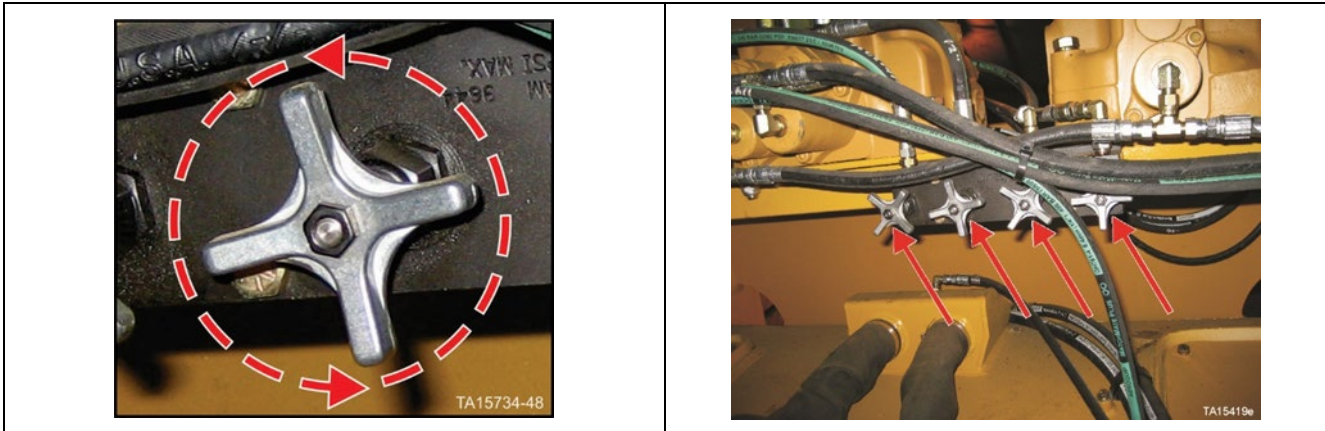

Figure 26. Pressure bleed down valves

## Remove the Tire

### Preferred Method

The following procedure is applicable to both front and rear wheel assemblies.

## NOTICE

The preferred method of handling the tires is with commercial truck-mounted equipment designed for this purpose. This equipment is available by contracting with a specialty tire handling equipment company.



Figure 27. Mechanical handler (preferred method)

- a. Hoist or jack the loader to a suitable height for removing the wheel and tire. Refer to “STRUCTURAL”, “JACKING INSTRUCTIONS”, located in Section 03 of the Service Manual, titled “MECHANICAL”.

## CAUTION

**DO NOT** lift the loader with the lift arms. Serious damage to the loader could occur.

## WARNING

**Explosion and struck by hazards exist if handling an inflated tire before mounting it on the machine. Bleed tire air pressure to 0 psi/bar before handling a tire. Install the tire and wheel assembly on the machine before inflating the tire. Failure to mount the tire and wheel assembly onto the machine before inflating the tire can cause explosion or struck by hazards resulting in severe injury or death.**

- b. Position the mechanical tire handler and secure the tire.
- c. Remove the capscrews to release the wheel and tire from the planetary drive hub.
  - Follow the appropriate bolt removal pattern shown in “Wheel Hub Capscrew Removal Specifications”, below in this document.
  - Retain hardware in a safe, clean place for re-use.

## WARNING

**Struck-by or crush hazards exists when removing the tire. It is essential to follow the appropriate incremental torque pattern for removal of wheel/tire assembly from the machine. Not following this pattern could cause some fasteners to become overloaded resulting in breakage and unplanned movement of the wheel/tire assembly or component damage. Refer to the illustrations in this document (below) for appropriate torque pattern to follow. Failure to follow the correct bolt removal pattern and procedure can cause Struck-by or crush hazards resulting in serious injury or death.**

## NOTICE

**The use of 1” drive impact socket, P/N 416-2114, is recommended for removing the wheel retaining capscrews. This socket has an outside diameter of 1.75” to fit between the planetary drive and wheel. Contact your authorized Komatsu Service Center or the Komatsu Parts Department in Longview, Texas to order.**

- d. Carefully lift and direct the wheel and tire away from the planetary drive assembly as required.

### Alternative Method

The following hoists and rigging are required for removal and installation of the wheel and tire assembly:

- A crane or jack suitable to lift the weight of the loader for removal of the wheel and tire is required. Refer to “STRUCTURAL, JACKING INSTRUCTIONS”, located in Section 3 of the Service Manual, for weight applicable to your machine. ALWAYS ALLOW A SAFETY MARGIN ABOVE THIS WEIGHT.
- A crane of suitable height and capacity to hoist the wheel and tire from the loader is required. ALWAYS ALLOW A SAFETY MARGIN ABOVE THE LISTED WEIGHT.

- Two (2) wire rope slings of equal length (36 ft. recommended), of sufficient capacity for lifting the applicable wheel and tire assembly weight (refer to illustration "Alternative tire handling method", below). ALWAYS ALLOW A SAFETY MARGIN ABOVE THIS WEIGHT. The slings should be covered with a protective rubber covering to prevent the cable from cutting into the tire (automotive heater hose or equivalent is recommended). The sling ends can also be fitted over a suitable lifting ring, if desired.

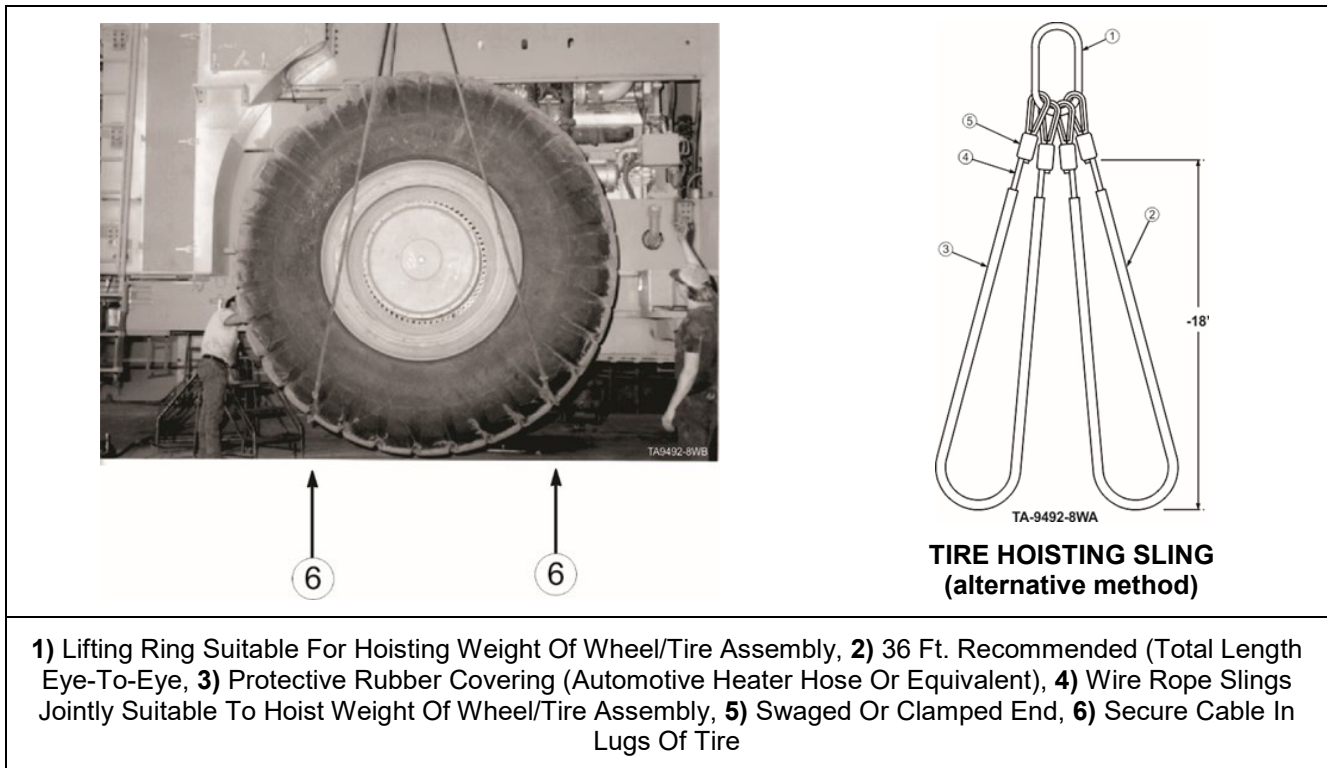

**Figure 28. Alternative tire handling method**

- Hoist or jack the loader to a suitable height for removing the wheel and tire. Refer to "STRUCTURAL", "JACKING INSTRUCTIONS", located in Section 03 of the Service Manual, titled "MECHANICAL".

## CAUTION

**DO NOT lift the loader with the lift arms. Serious damage to the loader could occur.**

## ⚠ WARNING

**Explosion and struck by hazards exist if handling an inflated tire before mounting it on the machine. Bleed tire air pressure to 0 psi/bar before handling a tire. Install the tire and wheel assembly on the machine before inflating the tire. Failure to mount the tire and wheel assembly onto the machine before inflating the tire can cause explosion or struck by hazards resulting in severe injury or death.**

- Position the crane hook, with slings attached, directly over the center of the tire.
- Lower the cables and secure them in the lugs of the tire, as shown in the illustration titled "Alternative tire handling method". Apply enough lift to hold the weight of the assembly.

- d. Remove the capscrews to release the wheel and tire from the planetary drive hub.
- Follow the appropriate bolt removal pattern shown in “Wheel Hub Capscrew Removal Specifications”, in this document.
  - Retain hardware in a safe, clean place for re-use.

## WARNING

Struck-by or crush hazards exists when removing the tire. It is essential to follow the appropriate incremental torque pattern for removal of wheel/tire assembly from the machine. Not following this pattern could cause some fasteners to become overloaded resulting in breakage and unplanned movement of the wheel/tire assembly or component damage. Refer to the illustrations in this document (below) for appropriate torque pattern to follow. Failure to follow the correct bolt removal pattern and procedure can cause Struck-by or crush hazards resulting in serious injury or death.

## NOTICE

The use of 1” drive impact socket, P/N 416-2114, is recommended for removing the wheel retaining capscrews. This socket has an outside diameter of 1.75” to fit between the planetary drive and wheel. Contact your authorized Komatsu Service Center or the Komatsu Parts Department in Longview, Texas to order.

- e. Carefully lift and direct the wheel and tire away from the planetary drive assembly as required.

## Tire and Rim - Demounting and Mounting

The following instructions and safety precautions are for the general maintenance, handling, and repair of the tire and rim assemblies on the machine.

## NOTICE

Persons NOT TRAINED in tire installation and tire removal on these heavy machines, MUST NOT PERFORM the work described in this publication. Severe injury or death may result because of failure to follow proper procedures.

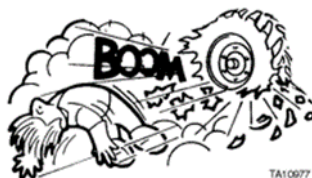

## WARNING

Explosion hazard exists if heating the tire or tire rim while the tire is still mounted and inflated. This means NO welding, grinding, using a cutting or heating torch or any other procedure that would cause extreme heat. Generating heat on the rim or tire of an inflated tire can cause an explosion hazard resulting in serious injury or death.

## NOTICE

Before attempting to perform any maintenance or repair to the tire and rim assemblies on the machine; it is **IMPORTANT** to pay close attention to all safety information within this section and to read and understand tire manufacturers' manuals on the mounting and dismounting of tires.

### Maintenance and Handling of Rims

Tubeless tire rims perform an important function as part of the assembly air seal. Proper care, therefore, must be taken not to distort or mutilate the rim parts because they must mate properly to form part of the basic air chamber. Since the rim base, bead seat bands, and flanges are endless, distortion may prevent easy assembly as well as possibly resulting in no seal. The following guidelines should be followed in the maintenance and handling of the rims on the machine:

- Never lift a rim by the valve hole.
- Never drop, tumble, or roll rim parts.
- Only dead blow hammers should be used in assembling rims.
- Check rim components periodically for fatigue cracks. Replace all cracked, badly worn, damaged, and severely rusted components.
- Clean rims and repaint to stop detrimental effects of corrosion. Be very careful to clean all dirt and rust from the lock ring gutter. This is important to secure the lock ring in its proper position.

## NOTICE

**A filter on the air inflation equipment to remove the moisture from the airline aids in the prevention of corrosion. The filter should be checked periodically to see that it is working properly.**



# Demounting Tire from Rim Assembly

This information section is to be applied only to tires that have already been removed from the machine.

## ⚠ WARNING

**Explosion and struck by hazards exist if demounting an inflated tire. Bleed tire air pressure to 0 psi/bar before demounting a tire. Explosion will occur if attempt is made to demount an inflated tire. Failure to bleed pressure to “0” psi/bar before demounting the tire can cause explosion or struck by hazards resulting in severe injury or death.**

Each wheel assembly consists of two formed steel sections, the rim base structure, and the bead seat band, with an inner and outer removable side ring flange, which holds the tire in alignment. An O-ring is installed between the upper part of the outer end of the base structure and below the bead band section to prevent air loss. A lock ring is then placed between the bead seat band and the outer edge of the inner base section and is locked in place by a drive key. Refer to illustrations “Typical rim assembly”, below, for correct sequence of assembly or disassembly of the applicable rim sections.

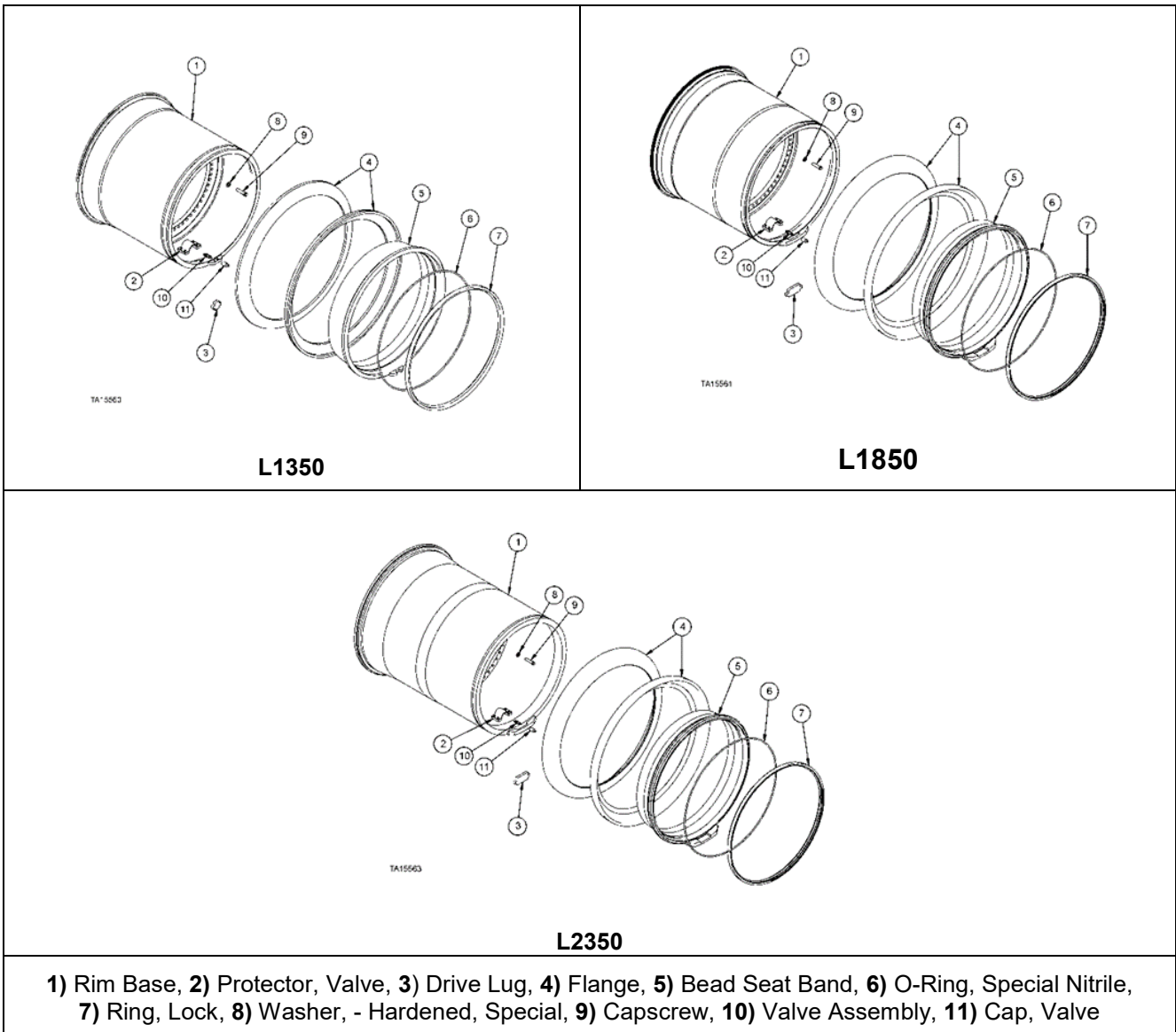

**Figure 30. Typical rim assembly**

- a. Place the deflated tire and rim on a flat surface with the outer rim facing up. Use blocking, when required, to support the rim with the tire clear of the ground or floor.
  - Refer to GOODYEAR OFF-ROAD RIM AND SAFETY AND SERVICE MANUAL, located in Section 3 entitled "VENDOR LITERATURE" of this Service Manual, for correct safety instructions and demounting procedures for removing a rim from a tire.

## Inspections of Demounted Tire and Rim Assemblies

### Tire Inspections

This information section is to be applied only to tires that have already been removed from the machine.

Serious tire damage may not be visible from the outside and a thorough inspection of the inside of the casing is important when a tire is dismounted.

1. Inspect for cuts or fabric breaks that have penetrated the tire body.
2. The casing should be inspected closely for any sharp pointed objects that may have penetrated the tire body, but are invisible from the outside.

### **WARNING**

**Explosion or fire hazards exist if using combustible detergents to clean rim parts or tire sections. Fire or explosion can occur if flammable fumes build up inside tire. Use only non-combustible fluids to clean the tire or rim. Using combustible detergents to clean rim parts or tire sections can cause explosion or fire hazards resulting in serious injury or death.**

3. All dirt, dust, water or other foreign matter should be cleaned from the inside of the tire.
4. Replace tubeless valve assembly if its condition is questionable.

### Rim Assembly Inspections

This information section is to be applied only to tires that have already been removed from the machine.

The rim parts used with tubeless tires form an important part of the air chamber. Therefore, they should be checked for distortion or mutilation that would prevent an effective air seal when the tire and rim are reassembled.

1. Carefully inspect rim components for cracks, bends distortion, or other damage. If any of these parts become damaged, they **MUST** be repaired or replaced with new parts. If this is not done, they may fly off during inflation, possibly causing injury.
  - a) Clean all rust and dirt from the rim parts and wheel and apply a coat of good grade primer paint. Allow the paint to dry thoroughly before remounting tire.
  - b) Rubber O-rings are air seals for tubeless tire and rim assemblies and therefore should be carefully handled to provide an airtight seal when the tire is remounted on the rim. **ALWAYS** use new O-rings when remounting tires.

## Mounting Rim Assembly to Tire - Important Safety Information

This information section is to be applied only to tires that have already been removed from the machine.

### **WARNING**

**Explosion hazard exists when inflating tires. Always use clean air when inflating tires. Refer to text “TIRE EXPLOSION (SAFETY HINTS)”, located in “SAFETY, WARNINGS, AND CAUTIONS” in this section, regarding clean inflation air and tire explosions. Failure to use clean air when inflating tires can cause an explosion hazard resulting in serious injury or death.**

1. **MAKE SURE** correct parts are being assembled. Refer to illustrations “Typical rim assembly”, (as applicable), for an illustration of the applicable rim assembly.
2. **DOUBLE CHECK** to make sure all rim components are properly seated prior to inflation.
3. **DO NOT** re-inflate a tire that has been run flat without first inspecting the tire, rim, and wheel assembly. Double check the lock ring for damage; make sure that it is secure in the gutter before inflating.
4. **DO NOT** seat rings by hammering while the tire is inflated. Do not hammer on an inflated or partially inflated tire and rim assembly.
5. **DO NOT** inflate tire before all side and lock rings are in place. Check components for proper assembly again after inflating to approximately 5 psi (0.34 bar).
6. Place the rim base structure on a flat surface. Use blocking as required to keep the tire clear of ground.
7. Refer to GOODYEAR OFF-ROAD RIM AND SAFETY AND SERVICE MANUAL, located in Section 3 titled “VENDOR LITERATURE” of this manual, for correct safety instructions and other procedures to mount rim to tire.

## Wheel Hub Capscrew Installation Torque Specifications

These guidelines should be followed for all new machines, for machines currently in service under normal operation, and for machines with remounted tire and rim assemblies.

### Safety Preparations

Use the following procedure to isolate energy sources before performing any removal, replacement, or installation procedures described in this document.

### **WARNING**

**Crush hazards exist if the machine is started or moved while work processes are being performed on the machine. Place bucket flat and level on the ground. Place frame lock in the locked position and lock out the machine’s starting capability before performing any work process. Follow all applicable lockout procedures and local rules and regulations for performing work processes. ANYONE performing inspections or service procedures to the machine should be familiar with ALL instructions and procedures contained in the machine’s SERVICE MANUAL. Crush hazard could occur if the machine is started or moves while any type of work process is being conducted on the machine, resulting in serious injury or death.**

- a. Stop the wheel loader on flat level ground.

- b. Move the frame lock to the locked position so that the frame cannot be steered.
- c. Place wheel chocks in front and behind each wheel.

**⚠ WARNING**

Crush hazards exist in machine pivot area and area between the tires. Do not enter these areas unless it is verified that the operator has control over the steering and that personnel locking the frame lock have good communication with the operator. Entering the pivot area and area between the tires while the machine is moving or pivoting (articulating) could cause crush hazards resulting in serious injury or death.

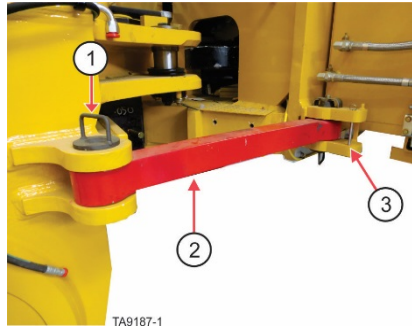

- 1) Retaining pin for locked position, 2) Frame lock - shown in locked position,
- 3) Retaining pin bracket for un-locked position

**Frame lock in locked position**

- d. Set bucket flat and level on the ground.
- e. Set the parking brakes.
- f. Shut off the engine.
- g. Turn the battery and engine isolation switches to the off position and install locks on the battery isolation switch.



**Figure 31. Battery Isolation Box – Battery isolation switch in OFF position with locks in place**

The following torque patterns (illustration for following titles located below in this document) for each specific machine model should be followed when installing and torquing the retaining bolts.

## NOTICE

**L-1350/L-1850/L-2350: Rim-to-planetary drive hub capscrew torque requirement: 1"- 8 UNC X 4", 12 pt. capscrew, lubricated with 30W motor oil on threads and under heads (refer to "Capscrew and Bolt-Nut Torque Specifications").**

- h. The use of 1"-drive impact socket P/N 416-2114 is recommended for torquing the wheel retaining capscrews. This socket has an outside diameter of 1.75" to fit between the planetary drive and wheel. Contact your authorized Komatsu Service Center or the Komatsu Parts Department in Longview, Texas, to order.
- i. Verify torque after first 2, 6, 14, and 100 hours of operation and every 500 hours thereafter.
- j. If no loose capscrews are found during the two-hour and six-hour verifications, then it is acceptable to perform spot checks on subsequent verifications.
- k. If any loose capscrews are found during the six-hour or 14-hour check, re-torque the loose capscrews and continue to verify the torque on four-hour intervals. If after four verifications of torque the capscrews continue to come loose, the wheel should be removed and all mating surfaces examined and cleaned as required.

## NOTICE

Refer to text titled "THE IMPORTANCE OF PROPER BOLT TORQUE AND GRADE IN MACHINE OPERATION", located in "Capscrew and Bolt-Nut Torque Specifications" for additional information concerning maintaining the proper bolt torque.

Follow the numbered sequence in incremental tightening until all capscrews are to the required torque. Do not tighten any one capscrew before others are drawn in incrementally.

## NOTICE

**BE SURE** all washers are installed on wheel attachment capscrews.

Hardened washers are required under the heads of the capscrews used to retain the rims to the planetary drives on ALL P&H wheel loader/dozer machines.

- Refer to Parts Manual for part numbers.

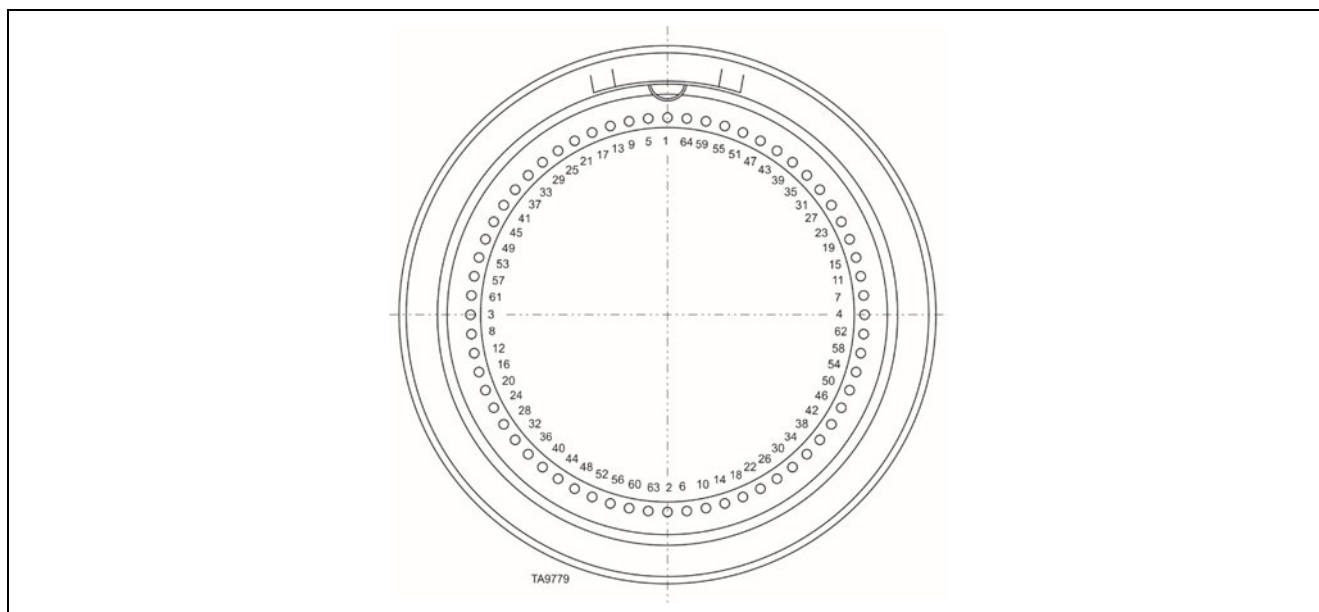

Figure 32. L-1350-L-1850-L-2350 wheel capscrew installation torque pattern – models 51 and 57 planetary drive

## Wheel and Tire Installation

### WARNING

Explosion and struck by hazards exist if handling an inflated tire before mounting it on the machine. Bleed tire air pressure to 0 psi/bar before handling a tire. Install the tire and wheel assembly on the machine before inflating the tire. Failure to mount the tire and wheel assembly onto the machine before inflating the tire can cause explosion or struck by hazards resulting in severe injury or death.

The following procedure is applicable to both front and rear wheel assemblies.

### Safety Preparations

Use the following procedure to isolate energy sources before performing any removal, replacement, or installation procedures described in this document.

### WARNING

Crush hazards exist if the machine is started or moved while work processes are being performed on the machine. Place bucket flat and level on the ground. Place frame lock in the locked position and lock out the machine's starting capability before performing any work process. Follow all applicable lockout procedures and local rules and regulations for performing work processes. ANYONE performing inspections or service procedures to the machine should be familiar with ALL instructions and procedures contained in the machine's SERVICE MANUAL. Crush hazard could occur if the machine is started or moves while any type of work process is being conducted on the machine, resulting in serious injury or death.

- a. Stop the wheel loader on flat level ground.
- b. Move the frame lock to the locked position so that the frame cannot be steered.

## ⚠ WARNING

Crush hazards exist in machine pivot area and area between the tires. Do not enter these areas unless it is verified that the operator has control over the steering and that personnel locking the frame lock have good communication with the operator. Entering the pivot area and area between the tires while the machine is moving or pivoting (articulating) could cause crush hazards resulting in serious injury or death.

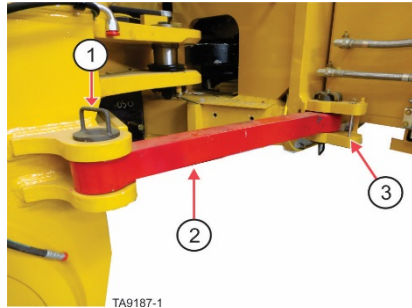

- 1) Retaining pin for locked position, 2) Frame lock - shown in locked position,  
3) Retaining pin bracket for un-locked position

### Frame lock in locked position

- c. Set bucket flat and level on the ground.
- d. Set the parking brakes.
- e. Shut off the engine.
- f. Place wheel chocks in front and behind each wheel.
- g. Turn the battery and engine isolation switches to the off position and install locks on the battery isolation switch.

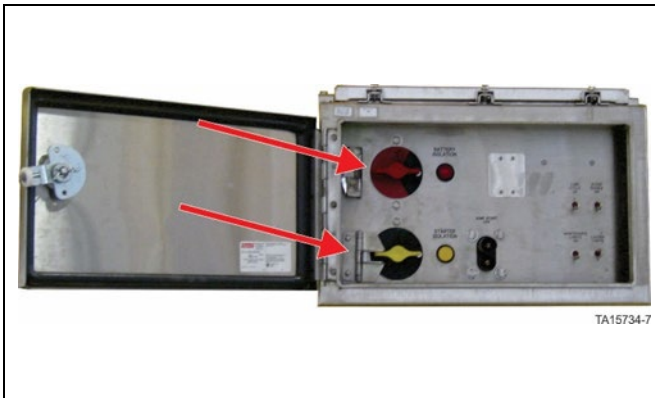

**Figure 33. Battery Isolation Box – Battery isolation switch in OFF position with locks in place**

- h. Release the air from the hydraulic reservoir by using the hydraulic reservoir air valve (ball valve) on top of the reservoir. The supply line from main air system will be blocked and reservoir air will vent out the hose that runs down the outside of the hydraulic reservoir.
  - Turn the handle to the up position as shown.

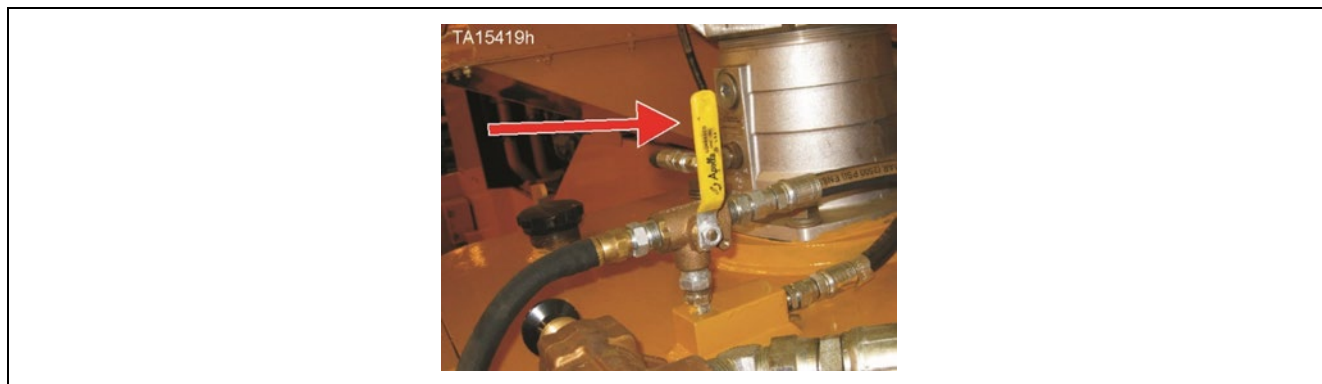
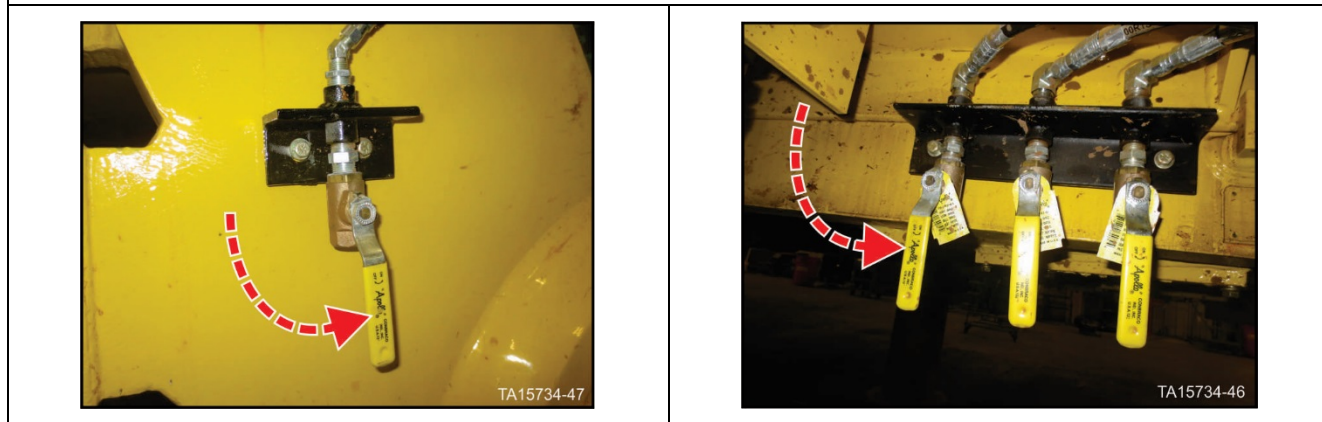

**Figure 34. Hydraulic reservoir air valve handle UP**

- i. Release the air from the various air storage reservoirs by opening all of the air bleed valves.

Three valves on right side of rear frame under hydraulic reservoir

One valve on right side of front frame near hoist cylinder ball cap



**Figure 35. Open air reservoir bleed valves**

**⚠ WARNING**

Crush hazards exist if all personnel are not cleared from the bucket and lift arm area before using the hydraulic hoist and bucket hydraulic pressure bleed down valves to relieve pressure from the hoist and bucket circuit. Clear all personnel from the area around the bucket and lift arms before operating hydraulic hoist and bucket hydraulic pressure bleed down valves. Using the hydraulic bleed down valves could result in some movement of the lift arms and bucket which could cause a crush hazard resulting serious injury or death.

- j. Use the hydraulic pressure bleed down valves located in the front frame underneath the Husco valves to bleed any stored pressure in the hoist and bucket cylinders.
- k. Turn each valve slowly counterclockwise as shown below and allow the pressure to bleed down.
  - Open the valve completely and leave it open during this procedure.

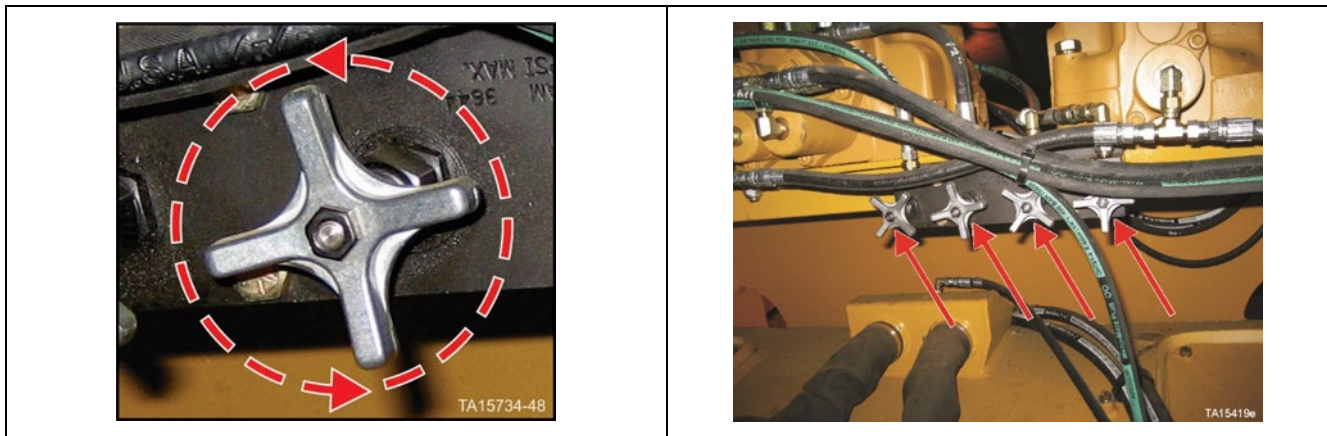

Figure 36. Pressure bleed down valves

- I. Hoist or jack the loader to a suitable height for installing the wheel and tire. Refer to “STRUCTURAL”, “JACKING INSTRUCTIONS”, located in Section 03 of the Service Manual, titled “MECHANICAL”.

## CAUTION

**DO NOT** lift the loader with the lift arms. Serious damage to the loader could occur.

## ⚠ WARNING

Explosion and struck by hazards exist if handling an inflated tire before mounting it on the machine. Bleed tire air pressure to 0 psi/bar before handling a tire. Install the tire and wheel assembly on the machine before inflating the tire. Failure to mount the tire and wheel assembly onto the machine before inflating the tire can cause explosion or struck by hazards resulting in severe injury or death.

## ⚠ WARNING

Struck-by or crush hazards exists when installing the tire and rim assembly. It is essential to follow the appropriate incremental torque pattern for installation of wheel/tire assembly on the machine. Not following this pattern could cause some fasteners to become overloaded resulting in breakage and unplanned movement of the wheel/tire assembly or component damage. Refer to the illustration “L-1350-L-1850-L-2350 wheel capscrew installation torque pattern – models 51 and 57 planetary drive” for appropriate torque pattern to follow. Failure to follow the correct bolt removal pattern and procedure can cause struck-by or crush hazards resulting in serious injury or death.

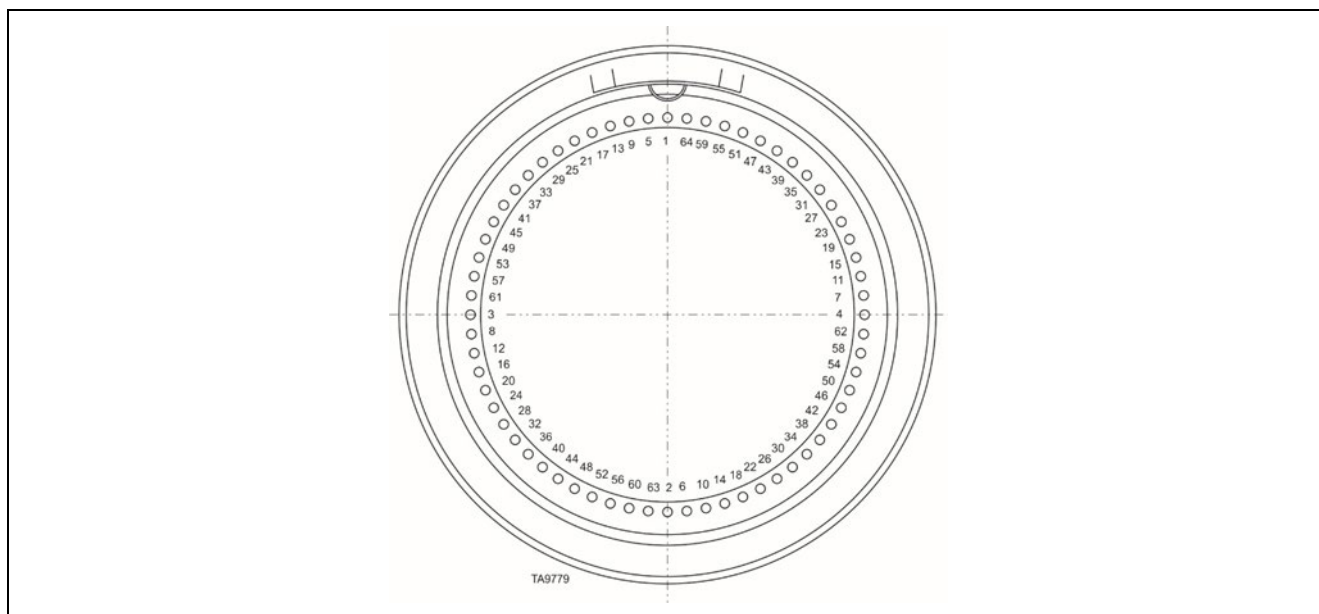

**L-1350-L-1850-L-2350 wheel cap screw installation torque pattern – models 51 and 57 planetary drive**

**Preferred Method:**

## NOTICE

The preferred method of handling the tires is with commercial truck-mounted equipment designed for this purpose. This equipment is available by contracting with a specialty tire handling equipment company. The following recommendations are made to aid in field removal/installation should commercial tire handling equipment not be available.

**Alternative Method:**

- A crane of suitable height and capacity to hoist the wheel and tire from the loader is required. ALWAYS ALLOW A SAFETY MARGIN ABOVE THE LISTED WEIGHT.
- Two (2) wire rope slings of equal length (36 ft. recommended), of sufficient capacity for lifting the applicable wheel and tire assembly weight (refer to illustration “Alternative tire handling method”, above). ALWAYS ALLOW A SAFETY MARGIN ABOVE THIS WEIGHT.
- The slings should be covered with a protective rubber covering to prevent the cable from cutting into the tire (automotive heater hose or equivalent is recommended). The sling ends can also be fitted over a suitable lifting ring, if desired.
- Position the crane hook, with slings attached, directly over the center of the tire.
- Lower the cables and secure them in the lugs of the tire, as shown in the illustration titled “Alternative tire handling method”. Apply enough lift to hold the weight of the assembly.

**Continue Either Method:**

- Carefully hoist the wheel and tire into position for mounting on the planetary drive. Line up of the wheel attachment cap screws can be accomplished by moving the wheel, left or right, in the direction of alignment.

- Mating surfaces on rim and planetary drive hub must be clean and free of oil and paint before the wheel is bolted to planetary drive.
- Lubricate the capscrew threads and under the head with SAE 30W motor oil before installation (refer to CAPSCREW LUBRICATION, below).
- Install the wheel attachment capscrews with hardened flatwashers (alternately opposite from one another) (refer to CAPSCREW/HARDENED FLATWASHER INSTALLATION – WHEEL ATTACHMENT). Refer to NOTE following. Start the capscrews by hand. Always ensure a minimum of at least three threads are engaged. If it is difficult to start the capscrews by hand, remove the individual capscrews and use a thread chaser to clean the tapped hole in the planetary drive. Additional capscrews should be installed in the same manner until all capscrews are secured and properly torqued.

## NOTICE

Refer to “Tire Inflation and Deflation Procedures”, above, before proceeding with inflation procedures.

- Inflate the tire to the pressure listed for the tire in the table titled “Tire size and inflation data – recommended cold tire inflation pressures”, within this section. There is also an instructional sign, which lists recommended tire pressures, located on the right hand side of the front frame at the pivot area of the machine.
- Front and rear pressure is different.
- Lower the machine to the ground.
- Move the frame lock to the unlocked position.
- Return the machine to operational condition.

## NOTICE

Verify torque on wheel attaching capscrews after the first 2, 6, 14, and 100 hours of operation and every 500 hours thereafter.

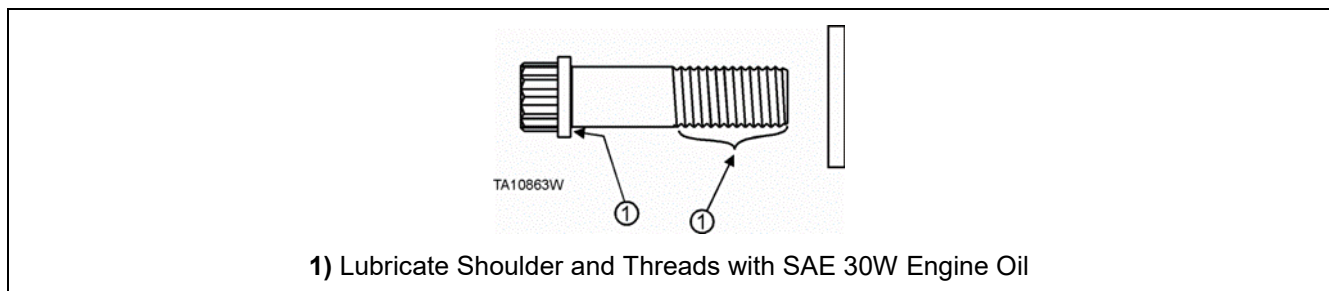

**Figure 37. Capscrew lubrication**

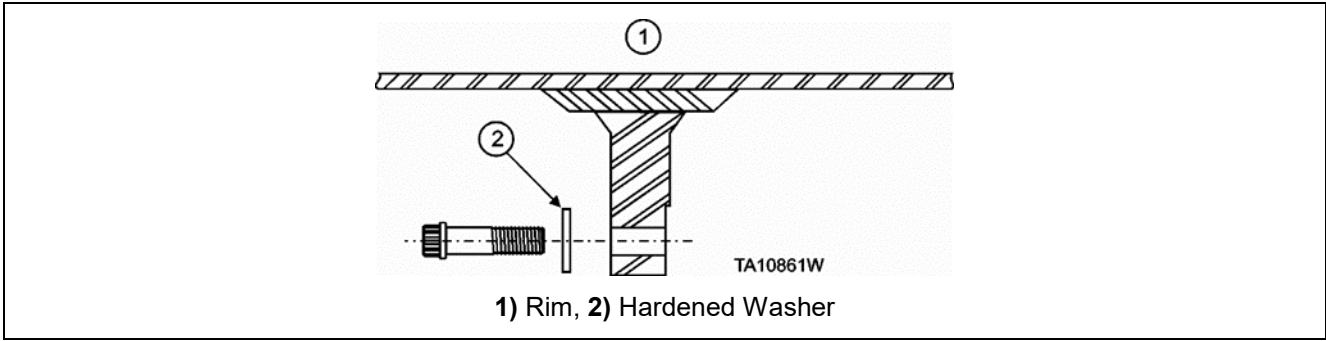

Figure 38. Capscrew/hardened flatwasher installation – wheel attachment

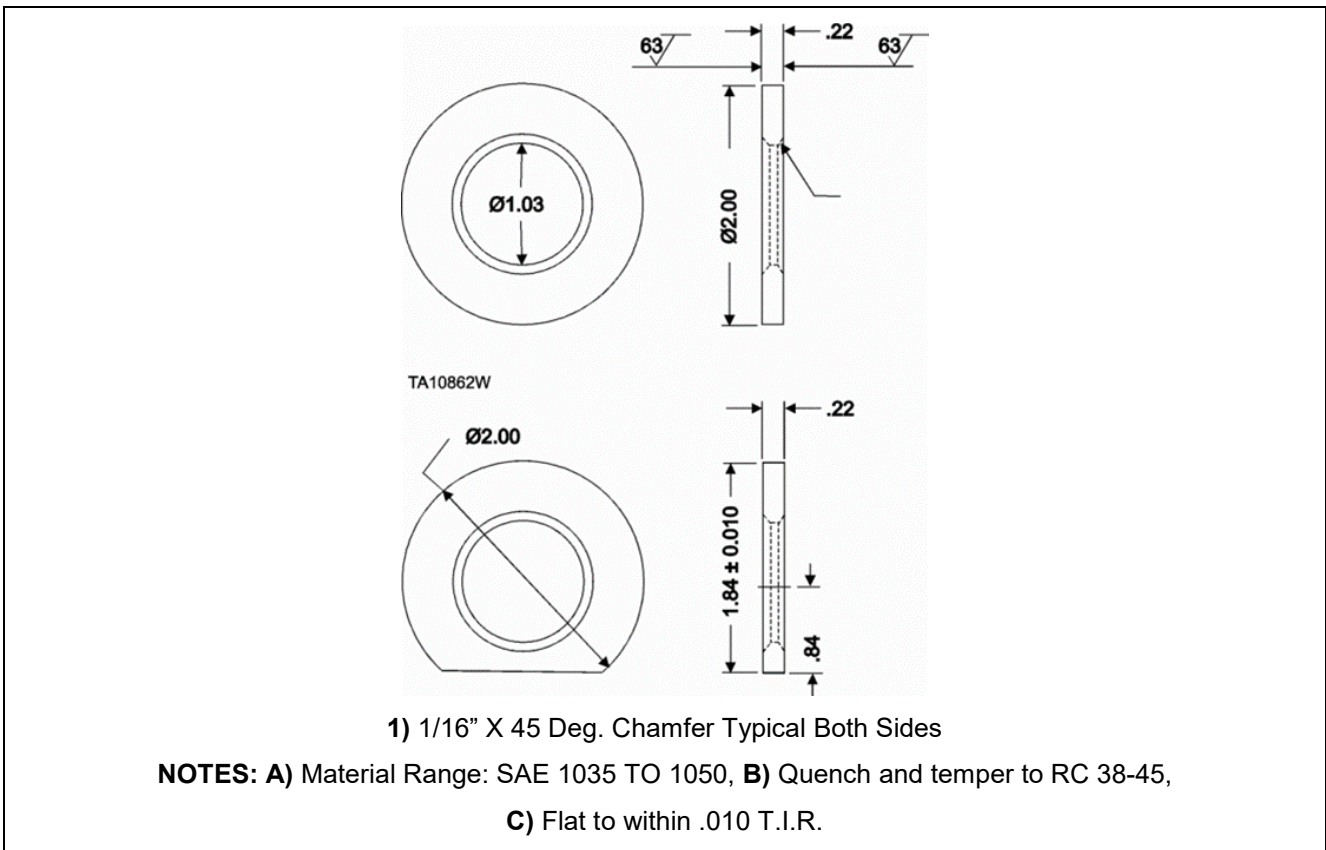

Figure 39. Hardened flatwasher – wheel installation

This Page Intentionally Left Blank

# Troubleshooting

## Tire Repairs

**Prompt repair of tire injuries will prevent small injuries from enlarging and causing tire failure.** Always use the best tire facilities available. Minor cuts, snags, or punctures should be repaired upon discovery. The following guidelines will help in the routine repair of tire injuries:

### WARNING

**Explosion and struck by hazards exist if handling an inflated tire before mounting it on the machine. Bleed tire air pressure to 0 psi/bar before handling a tire. Install the tire and wheel assembly on the machine before inflating the tire. Failure to mount the tire and wheel assembly onto the machine before inflating the tire can cause explosion or struck by hazards resulting in severe injury or death.**

- Skive, with a sharp-pointed knife, around any cut in the tire tread that is of sufficient depth or shape to hold pebbles or dirt. The angle of the skive should be no more than sufficient to expel all foreign material and should not extend deeper than the breaker. The skive should not go to the bottom of the hole.
- Tires with shallow cuts, if treated promptly, may be allowed to continue in service. If the cut extends deeper into the carcass, the tire should be removed for repair. Ordinary tubeless tire punctures can be repaired without removing the tire from the rim. Use tire repair plugs and follow guidelines given by the tire manufacturer.
- The tire must be removed from the rim to repair larger punctures or cuts. Irregular shaped punctures or cuts less than 1/2 inch in size can be repaired with a plug and a hot patch. Insert a repair plug into the hole to keep out moisture and to back up the hot patch. Trim the plug off flush with the inside of the casing, buff and apply the hot patch according to the instructions supplied with the hot patch equipment.
- Punctures 1/2 inch or larger, large cuts or bruise breaks require sectional or reinforced vulcanized repair. Cover the repair patch with a layer of cushion gum after application to the tubeless tire to insure airtight repair. Any cords of the inside ply that are exposed in buffing and are not covered with repair patch must be coated with cushion gum to prevent air leakage into the carcass plies on tubeless tires.

## Recapping and Retreading

There are two general methods employed in restoring tread surface to off-highway tires: recapping and retreading.

**A recapped tire** has a new tread cured right over the old tread surface.

**A retreaded tire** has the old tread removed entirely and a new tread cured directly onto the body of the tire.

A tire can be recapped or retreaded if the cord body is free of cuts, bruises, and separation and is thoroughly sound, including previous repairs.

### NOTICE

**Consult the tire manufacturer for specific recommendations on tire recapping and retreading.**

## Additional Tire Information and Warranty

For additional information concerning servicing, proper inflation pressure, warranty, or repairs consult the respective tire manufacturer's representative in your area.

### Parts Storage

- If rim parts are stored outdoors, they should be given a protective coat of a good commercial primer.
- Similar parts should be stacked together neatly to prevent distortion.
- O-rings are seals and should be carefully stored in a cool, dry place where they will not be damaged.
- Valves also should be stored in a cool, dry, and clean place.

### Storage and Handling of Tires

**The best care given to tires in service, by operators and maintenance personnel, can be completely nullified by careless storage.** Time is not the only contributing factor to deterioration of rubber products.

1. **Storage:** To avoid premature aging and degradation of tires during storage, it is necessary to protect them from:
  - Changes of temperature, drafts, extreme heat (more than 100° F [37.7 ° C]) and humidity.
  - Ozone sources, such as welders, spark-producing motors, mercury vapor quartz bulbs, and battery chargers with mercury rectifiers.
  - Direct exposure to the sun can damage tires. Stored tires should be carefully covered with a tarpaulin or some other suitable material, such as opaque plastic sheeting, to prevent contact with the contaminants listed above.
  - Distortion, such as caused by stacking can also damage tires. Upright positioning of tires is preferred over stacking to minimize distortion and stress. Horizontal stacking may compress the tire walls making inflation difficult. If tires are stored in racks, the lower supporting members should provide as broad a surface as possible to the tire tread to avoid concentration of load.

## NOTICE

**Tires should be stored to allow the oldest ones to be used first.**

2. **Handling:** The following guidelines will help eliminate deterioration of the beads and resultant tire failures:
  - Do not lift a tire by the beads directly with a crane's hook.
  - Use slings or chains to lift tires that are protected with a rubber covering.
  - Pick up tires under the tread and not by the beads when using a forklift.
  - If a forklift truck is used to handle tires, it should be equipped with broad well-rounded arms that evenly distribute the load and prevent damage to the tire bead. When using a fork truck to position tires, do not scrape the forks across the bead.

- For all tires shipped with bead protectors, leave this protection on until mounting time. Also, save the protectors as they can be used to cover a tire's bead when it is dismounted for recapping, retreading, or repair.

## NOTICE

**Consult the tire manufacturer for specific recommendations on tire storage and handling. Refer to the section of this manual entitled MACHINE STORAGE PROCEDURES for additional information concerning the maintenance of the tires mounted on machines placed in storage.**

This Page Intentionally Left Blank

# Capscrew and Bolt-Nut Torque Specifications

There are some exceptions to the torques provided on the following pages. Reduced torques are specified in the planetary drive rebuild manual, for the capscrews holding the planetary drive covers, due to a copper sealing washer under the head of the capscrew.

The torque specifications on this chart apply only to Grade 8 bolts, black or gold colored, and 12PT black-colored alloy steel capscrews. 12PT capscrews with gold-colored zinc chromate plating are excluded from these specifications and the zinc chromate 12PT capscrews should not be used on loaders or dozers. (except for planetary drive covers)

These torque values are for normal routine operations. If doing component rebuilds or any other abnormal machine component assembly/disassembly, please contact the factory for these values for specific instances.

 <p style="text-align: right; font-size: small;">TA15358A</p>	 <p style="text-align: right; font-size: small;">TA15358B</p>	 <p style="text-align: left; font-size: small;">TA15356-1</p>
<p style="text-align: center;">Does not apply <b>X</b></p>	<p style="text-align: center;">12PT Alloy Capscrew <b>✓</b></p>	<p style="text-align: center;">Grade 8 Bolt <b>✓</b></p>

## NOTICE

**Please note the additional tables for exceptions to the torque values for items such as Lift Arm Ballcaps, Super Nuts and steering pin bolts with drilled grease passages.**

Please direct any questions to Komatsu Product Support.

Capscrew and Bolt-Nut Torque Specifications Chart

**Standard SAE G8 and Alloy Steel and Hex Socket Capscrews**

Size	Thread	GRADE 8 Fasteners		Alloy Steel 12PT. and Hex Socket Capscrews	
		USA Units lb-ft	Metric Units N-m	USA Units lb-ft	Metric Units N-m
		**Lubed	**Lubed	**Lubed	**Lubed
1/4 (0.25)	20 UNC	9	13	12	16
	28 UNF	10	14	14	19
5/16 (0.3125)	18 UNC	18	25	24	33
	24 UNF	20	27	27	37
3/8 (0.375)	16 UNC	33	45	45	61
	24 UNF	37	50	50	68
7/16 (0.4375) (* See Note below)	14 UNC	52	71	70	95
	20 UNF	58	79	79	107
1/2 (0.5) (* See Note below)	13 UNC	80	109	108	146
	20 UNF	90	122	122	165
5/8 (0.625)	11 UNC	159	216	203	275
	18 UNF	180	244	230	312
3/4 (0.75)	10 UNC	282	383	361	490
	16 UNF	315	427	403	546
1 (1.0) (*** See Note below)	8 UNC	682	925	872	1182
	14 UNS	764	1,036	977	1325
1-1/8 (1.125)	7 UNC	966	1310	1235	1674
	12 UNF	1083	1468	1385	1878
1-1/4 (1.25) (**** See Note below)	7 UNC	1,363	1,848	1744	2365
	12 UNF	1,509	2,046	1930	2617
1-1/2 (1.5)	6 UNC	2,371	3,215	3033	4113
	12 UNF	2,668	3,618	3413	4628
* See Special Torque Specifications for ROPS super nut. ** See page 4 for specifications for "LUBED" – engine oil on threads and shoulder. *** See Special Torque Specifications for 950/1150 steering pins.			*** This bolt is UNS (with 14 threads per inch), it is NOT UNF. It is a unique thread count bolt. **** See Special Torque Specifications for loader lift arms and 1350/1850/2350 steering pins.		

**Standard Metric Bolts and Grades (SAE J1701M)**

Size (mm)	Pitch (mm)	Property Class 8.8		Property Class 10.9		Property Class 12.9	
		USA Units lb-ft	Metric Units N-m	USA Units lb-ft	Metric Units N-m	USA Units lb-ft	Metric Units N-m
		** Lubed	** Lubed	** Lubed	** Lubed	** Lubed	** Lubed
6	1.00	6	8	8	11	10	13
7	1.00	10	13	14	19	16	22
8	1.25	14	19	20	27	24	32
10	1.50	28	38	40	54	47	63
12	1.75	49	66	70	94	81	110
14	2.00	77	105	111	150	130	176
16	2.00	121	164	173	235	202	274
18	2.50	167	226	239	324	279	378
20	2.50	244	331	337	458	394	535
24	3.00	422	572	584	791	682	925

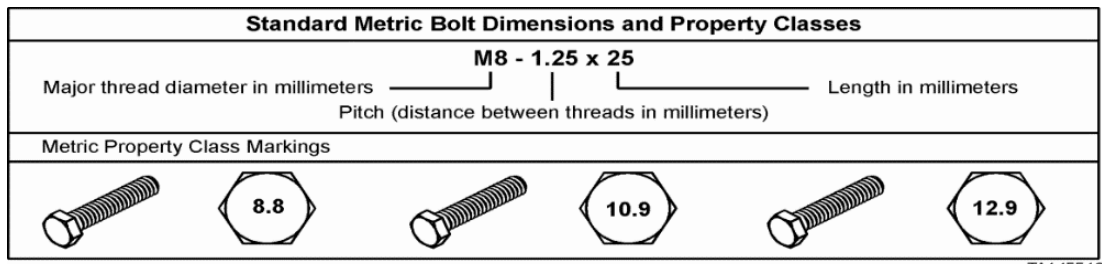

Capscrew and Bolt-Nut Torque Specifications

**Special Torque Specifications**

**Alloy Steel 12PT. Capscrew for Wheel Loader Lift Arm Ballcaps**

Size	Type	Thread	USA Units	Metric Units	Application
			lb-ft	N-m	
			<b>**Lubed</b>	<b>**Lubed</b>	
1-1/4 (1.250)	12PT. capscrew F-C on head	7 UNC	1900	2577	LHD, L-950, L-1150, L-1350, L-1850, and L-2350 (Lift arm ball caps only)
1-1/4 (1.250)	12PT. capscrew B-7 on head	12 UNF	1320	1790	L-1000-L-1100 (Lift arm ball caps only)

**Steering Pins (Hex Head Bolt)**

Size	Type	Thread	USA Units	Metric Lubed	Application
			lb-ft	N-m	
			<b>** Lubed</b>	<b>** Lubed</b>	
1 (1.0)	Bolt (drilled center)	8UNC	425	576	LHD, L-950, D-950, L-1150 (Steering Pins)
1-1/4 (1.250)	Bolt (drilled center)	7UNC	850	1152	L-1350, L-1850, L-2350 (Steering Pins)





**Aluminum 12pt. Capscrews used for Motor Pinion Balancing**

Size	Type	Thread	USA Units (lb-ft)		Metric Units (N-m)	
			Dry	**Lubed	Dry	**Lubed
3/4 (0.75)	Aluminum	16 UNF	114	86	155	117
3/4 (0.75)	Aluminum 2024-T4	16 UNF	150	113	203	153
15/16 (.9375)	Aluminum 6061 T6	12 NF	217	163	294	221
15/16 (.9375)	Aluminum 2024-T4	12 NF (2 START)	285	214	387	290

**2-Thread (2-Start) Steel 12PT. Capscrews**

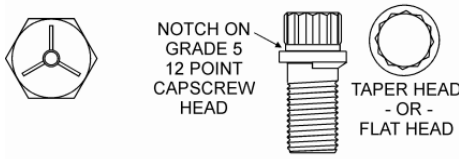
Size	Type	Thread	USA Units	Metric Units
			lb-ft	N-m
			<b>** Lubed</b>	<b>** Lubed</b>
3/8 (.3750)	12PT.	24 NF	25	34
9/16 (.5625)	12PT.	18 NF	87	119
15/16 (.9375)	12PT.	14 NF	428	584
1-5/16 (1.325)	12PT.	12 NF	1216	1660

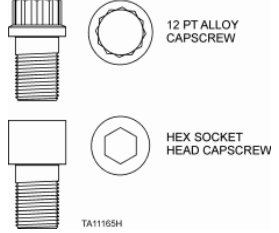
**Bolt and Capscrew Markings on Head**

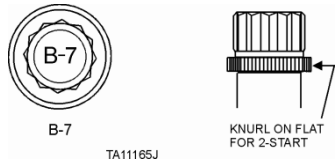
<p><b>GRADE 5 BOLTS &amp; CAPSCREWS</b> (*TORQUE TO 70% OF GRADE 8 VALUES)</p>  <p>NOTCH ON GRADE 5 12 POINT CAPSCREW HEAD</p> <p>TAPER HEAD - OR - FLAT HEAD</p> <p>(OLD LeTourneau manufactured capscrews)</p> <p>TA11185G</p>	<p><b>GRADE 8 MARKINGS ON BOLT HEAD</b></p>  <p>TA11185E</p>	 <p>12 PT ALLOY CAPSCREW</p> <p>HEX SOCKET HEAD CAPSCREW</p> <p>TA11165H</p>
<p><b>Typical Markings on Alloy Capscrew Heads</b></p>	<p><b>Typical B-7, 2-Start</b></p>	
 <p>ALL PRO    FERRY    DARLING    CARDINAL    SOCKET HEAD</p> <p>TA11165I</p>	 <p>B-7</p> <p>TA11165J</p> <p>KNURL ON FLAT FOR 2-START</p>	
<p>** See "Key Items" for specifications for "LUBED" – engine oil on threads and shoulder.</p>		

## Capscrew and Bolt-Nut Torque Specifications

### Key Items

- “LUBED” is defined as having the threads and under the head lubricated with engine oil. Engine oil is defined as SAE 30 or 40 weight oil, including multi viscosity grades 5W-30 through 15W-40. No other lubricant (such as anti-seize, MolyKote, copper coat, grease, etc.) is permitted unless specifically called out in a Komatsu procedure.

**\*\*LUBED = Lubricated with engine oil on threads and under head**  
 (SAE 30 or 40 weight oil, including multi viscosity grades 5W-30 through 15W-40)



**NOTE:** No other lubricant (such as anti-seize, never seize, MolyKote, copper coat, grease, etc.) is permitted unless specifically called out in a Komatsu procedure.

- All capscrews and bolts should be started by hand until a minimum of three (3) threads are engaged prior to any air impact equipment being used.
- If a procedure in a Rebuild Manual, Repair and Overhaul or Operating and Service Manual calls for the use of Loctite® threadlocker on the threads, the torque specification for “lubed” should be used. The threads on both the fastener and mating part should be thoroughly cleaned with a proper solvent prior to use of Loctite®. The Loctite® thread sealant should only be used on the threads - not the head.
- Certain applications in components such as drivers or lift arm ball caps may specify a FERRY brand of capscrew. Use only FERRY brand capscrews in these applications.
- Komatsu, recommends that any old 12PT. Komatsu-fabricated (fabrication was stopped many years ago) capscrew (refer to illustration under BOLT AND CAPSCREW MARKINGS ON HEAD) be replaced at the time of repair with alloy capscrews. If new capscrews are not available, then the Komatsu-fabricated capscrews should only be torqued to Grade 5 specifications (70% of Grade 8 value - lubed).
- The torque specifications on the charts on page 2 only apply to Grade 8 bolts, metric bolts and 12PT. black-colored alloy steel capscrews. Capscrews with gold-colored zinc chromate plating are excluded from these specifications and these capscrews should not be used on loaders or dozers except for driver covers.

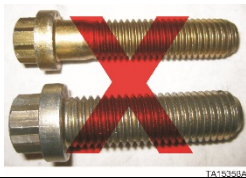

Does not apply X

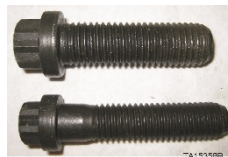

12PT Alloy Capscrew ✓



Grade 8 Bolt ✓

- **CLEANING:** It is mandatory to remove all paint, rust and debris from all mating surfaces, surfaces under the head of the bolt or capscrew and threads prior to installation and torquing of all bolts and capscrews.



Arrow indicates location to be cleaned



Cleaning paint and rust prior to torquing